

Copyright (C) Nokia Corporation. All rights reserved.
 THIS DRAWING IS PROTECTED BY COPYRIGHT AS AN UNPUBLISHED WORK.
 UNAUTHORIZED REPRODUCTION OF THIS DRAWING IS NOT PERMITTED.
 THIS DRAWING CONTAINS PROPRIETARY AND CONFIDENTIAL INFORMATION.
 This document is property of Nokia Corporation

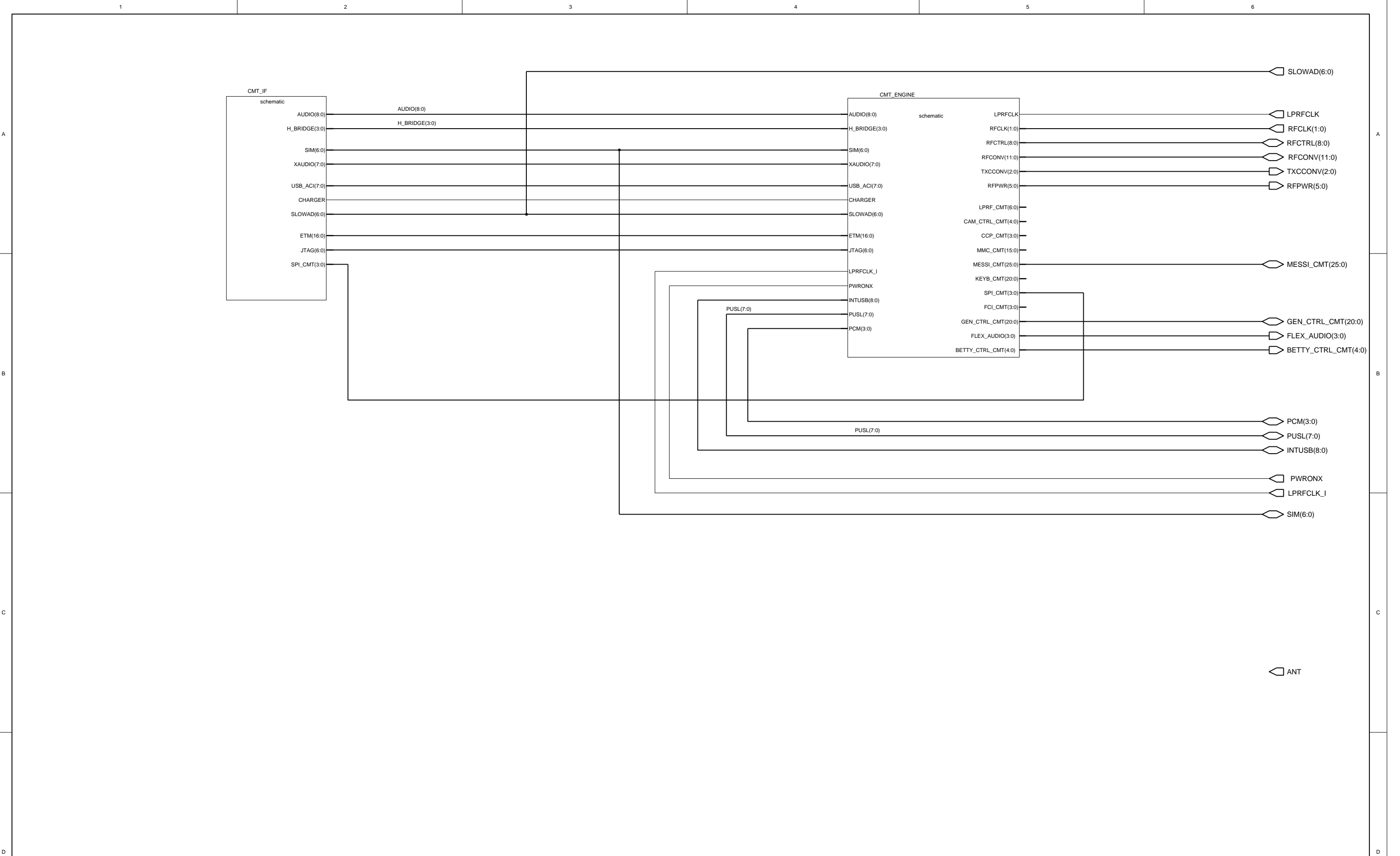

Name	BB Top Level	Appr	dd-mmm-yy
Assoc	Vilbet	Build	B 1.0
Des.	ILJARVIN		18-Aug-03
Dr.	TKOIVUSA		03-Jan-07
File	/nokia/sa_nmp/groups/p3047/rm-208/1yb/1yb_07/SYS		Sheet 03 of yy 0 (01)
Proj	WG3.2	Drw.	Print Yes v. 02 Edit 2



ANT

Copyright (C) Nokia Corporation. All rights reserved.
 THIS DRAWING IS PROTECTED BY COPYRIGHT AS AN UNPUBLISHED WORK.
 UNAUTHORIZED REPRODUCTION OF THIS DRAWING IS NOT PERMITTED.
 THIS DRAWING CONTAINS PROPRIETARY AND CONFIDENTIAL INFORMATION.
 This document is property of Nokia Corporation



Name	BB Top Level	Appr	dd-mmm-yy
Assoc	Villie	Des.	KAYRA 14-Jan-03
File	/nokia/sa_nmp/groups/p3047/rm-208/1yb/1yb_07/cellular	Dr.	TKOIVUSA 03-Jan-07
Proj	CBB5X	Sheet	xx of yy 0 (01)
		Print	Yes v. 0 Edit 2

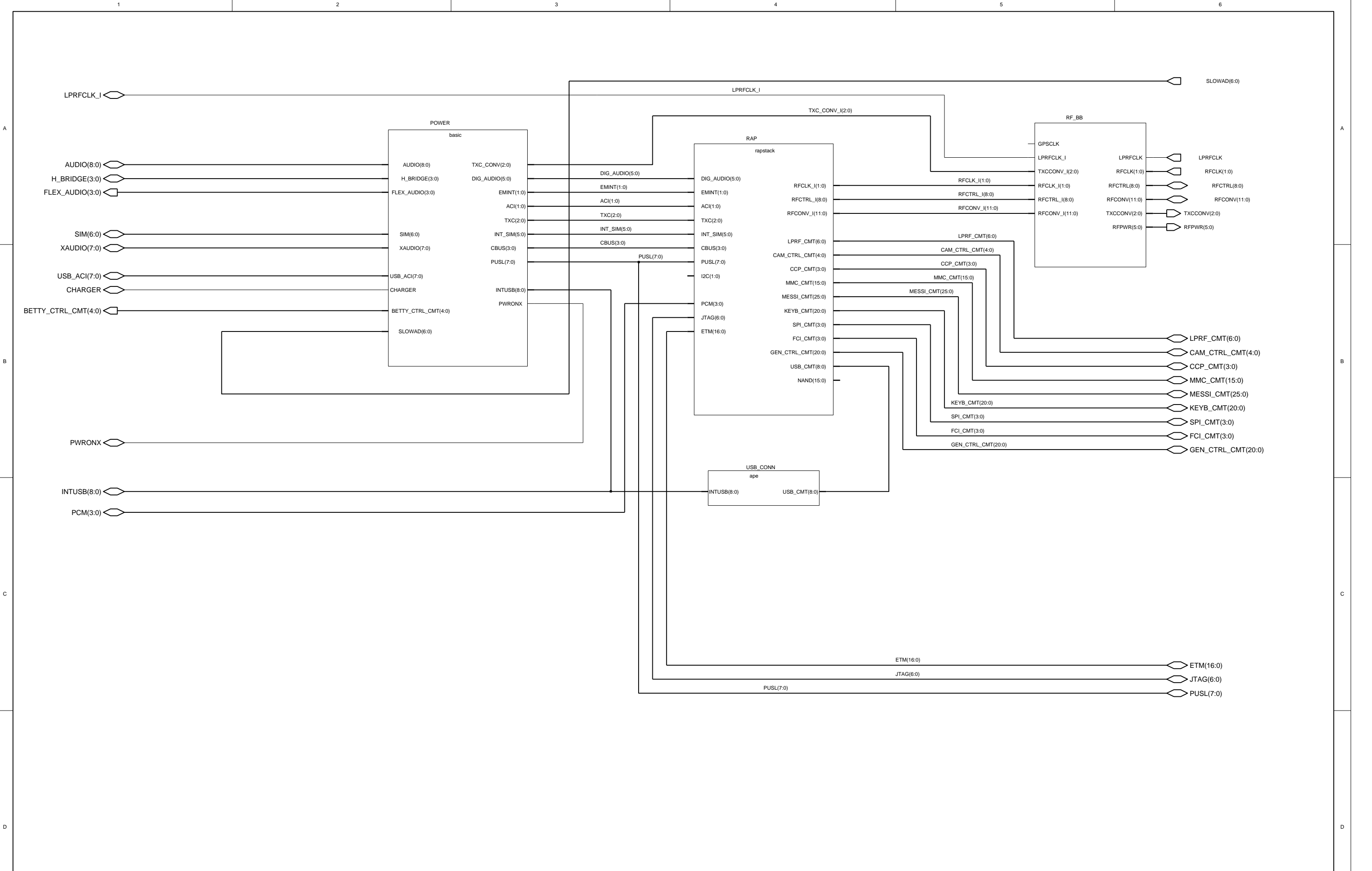

Copyright (C) Nokia Corporation. All rights reserved.
 THIS DRAWING IS PROTECTED BY COPYRIGHT AS AN UNPUBLISHED WORK.
 UNAUTHORIZED REPRODUCTION OF THIS DRAWING IS NOT PERMITTED.
 THIS DRAWING CONTAINS PROPRIETARY AND CONFIDENTIAL INFORMATION.
 This document is property of Nokia Corporation



Name	CMT_Engine Top level	Appr	dd-mmm-yy
Assoc	Engine Release Database	Des.	ArKa 27-May-03
		Dr.	TKOIVUSA 03-Jan-07
File	/nokia/sa_nmp/groups/p3047/rm-208/1yb/1yb_07/cellular/cmt_engine		Sheet xx of yy 0 (01)
Proj	Cement	Draw.	Print Yes v. 0.0 Edit 2

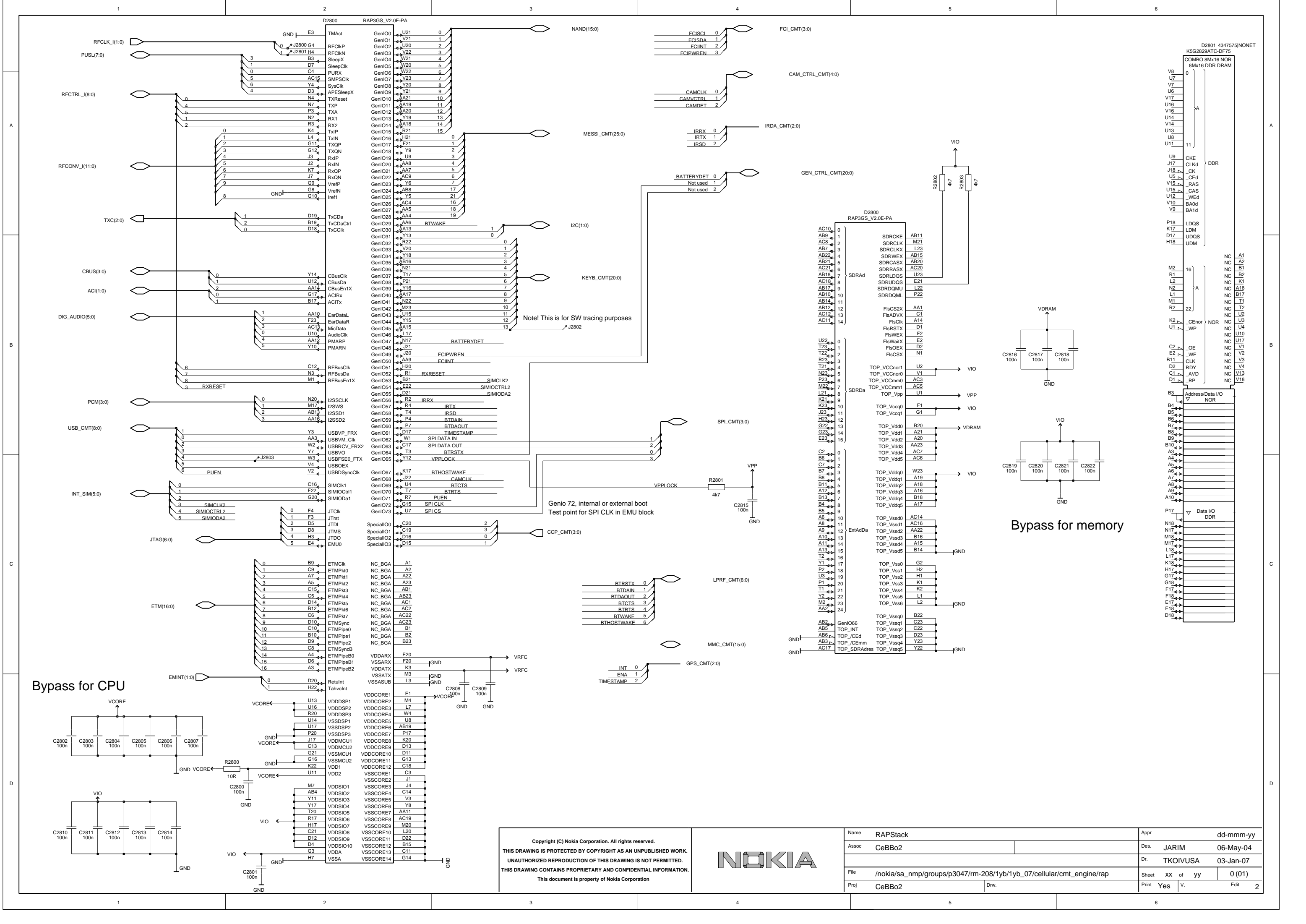

Bypass for CPU

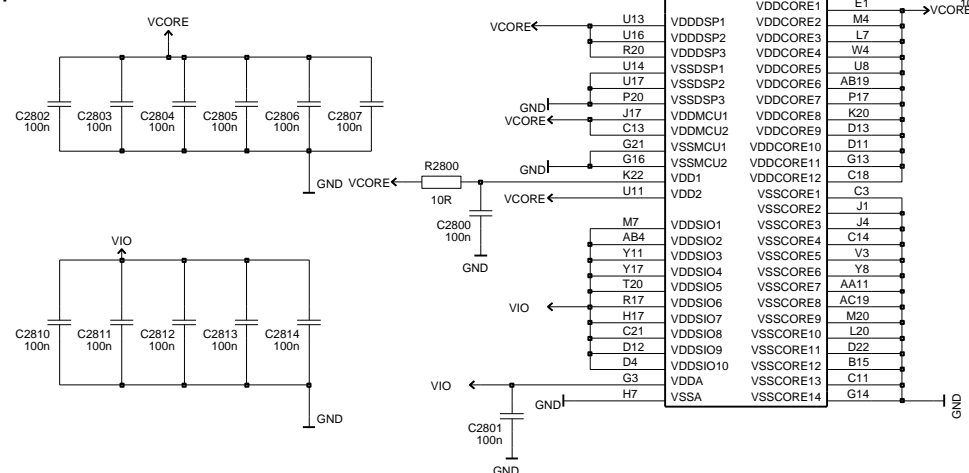

Bypass for memory

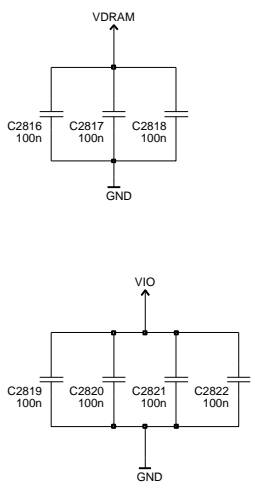

Copyright (C) Nokia Corporation. All rights reserved.
 THIS DRAWING IS PROTECTED BY COPYRIGHT AS AN UNPUBLISHED WORK.
 UNAUTHORIZED REPRODUCTION OF THIS DRAWING IS NOT PERMITTED.
 THIS DRAWING CONTAINS PROPRIETARY AND CONFIDENTIAL INFORMATION.
 This document is property of Nokia Corporation



Name	RAPStack	Appr	dd-mmm-yy
Assoc	CeBBo2	Des.	JARIM 06-May-04
File	/nokia/sa_nmp/groups/p3047/rm-208/1yb/1yb_07/cellular/cmt_engine/rap	Dr.	TKOIVUSA 03-Jan-07
Proj	CeBBo2	Sheet	xx of yy 0 (01)
		Print	Yes v. Edit 2

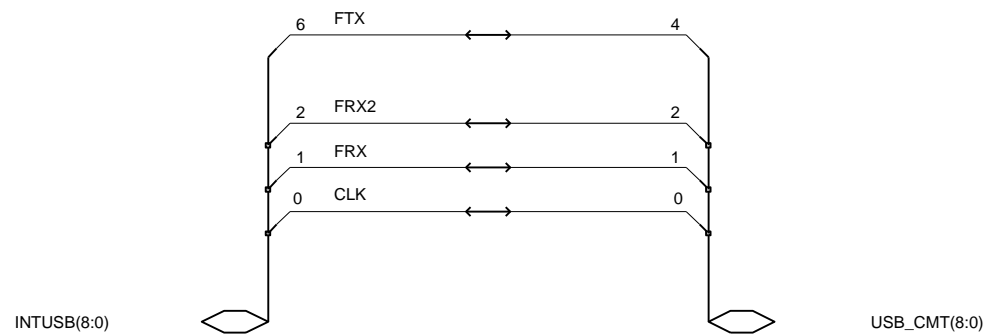

Copyright (C) Nokia Corporation. All rights reserved.
 THIS DRAWING IS PROTECTED BY COPYRIGHT AS AN UNPUBLISHED WORK.
 UNAUTHORIZED REPRODUCTION OF THIS DRAWING IS NOT PERMITTED.
 THIS DRAWING CONTAINS PROPRIETARY AND CONFIDENTIAL INFORMATION.
 This document is property of Nokia Corporation



Name	USB Connections with APE	Appr	dd-mmm-yy
Assoc	Engine Release Database	Des.	KatjaKnu 04-Jun-03
		Dr.	TKOIVUSA 03-Jan-07
File	/nokia/sa_nmp/groups/p3047/rm-208/1yb/1yb_07/cellular/cmt_engine/usb_conn	Sheet	XX of yy 0 (01)
Proj	Cement	Drw.	Print Yes V. 0.0 Edit 2

CBB5X

TOP SHEET

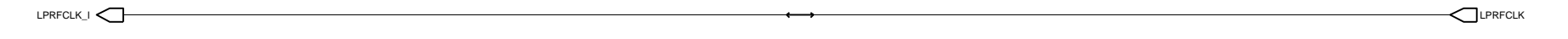
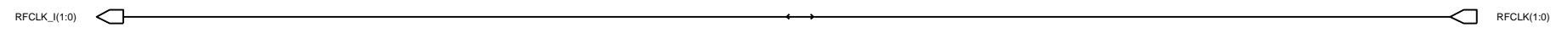

GPSCLK

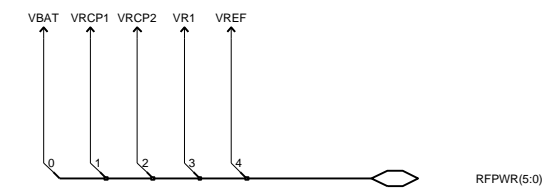
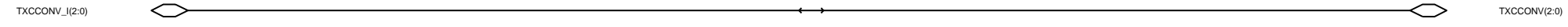
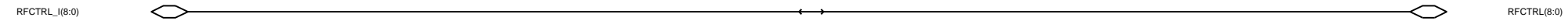
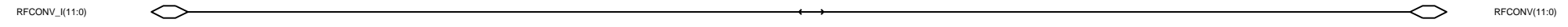

Copyright (C) Nokia Corporation. All rights reserved.
 THIS DRAWING IS PROTECTED BY COPYRIGHT AS AN UNPUBLISHED WORK.
 UNAUTHORIZED REPRODUCTION OF THIS DRAWING IS NOT PERMITTED.
 THIS DRAWING CONTAINS PROPRIETARY AND CONFIDENTIAL INFORMATION.
 This document is property of Nokia Corporation



Name	RF IF	Appr	dd-mmm-yy
Assoc	Charlie S0.2W	Des.	15-Jan-03
File	/nokia/sa_nmp/groups/p3047/rm-208/1yb/1yb_07/cellular/cmt_engine/rf_bb	Dr.	TKOIVUSA 03-Jan-07
Proj	CBB5X	Sheet xx of yy	0 (01)
	Draw.	Print Yes v. 0	Edit 2

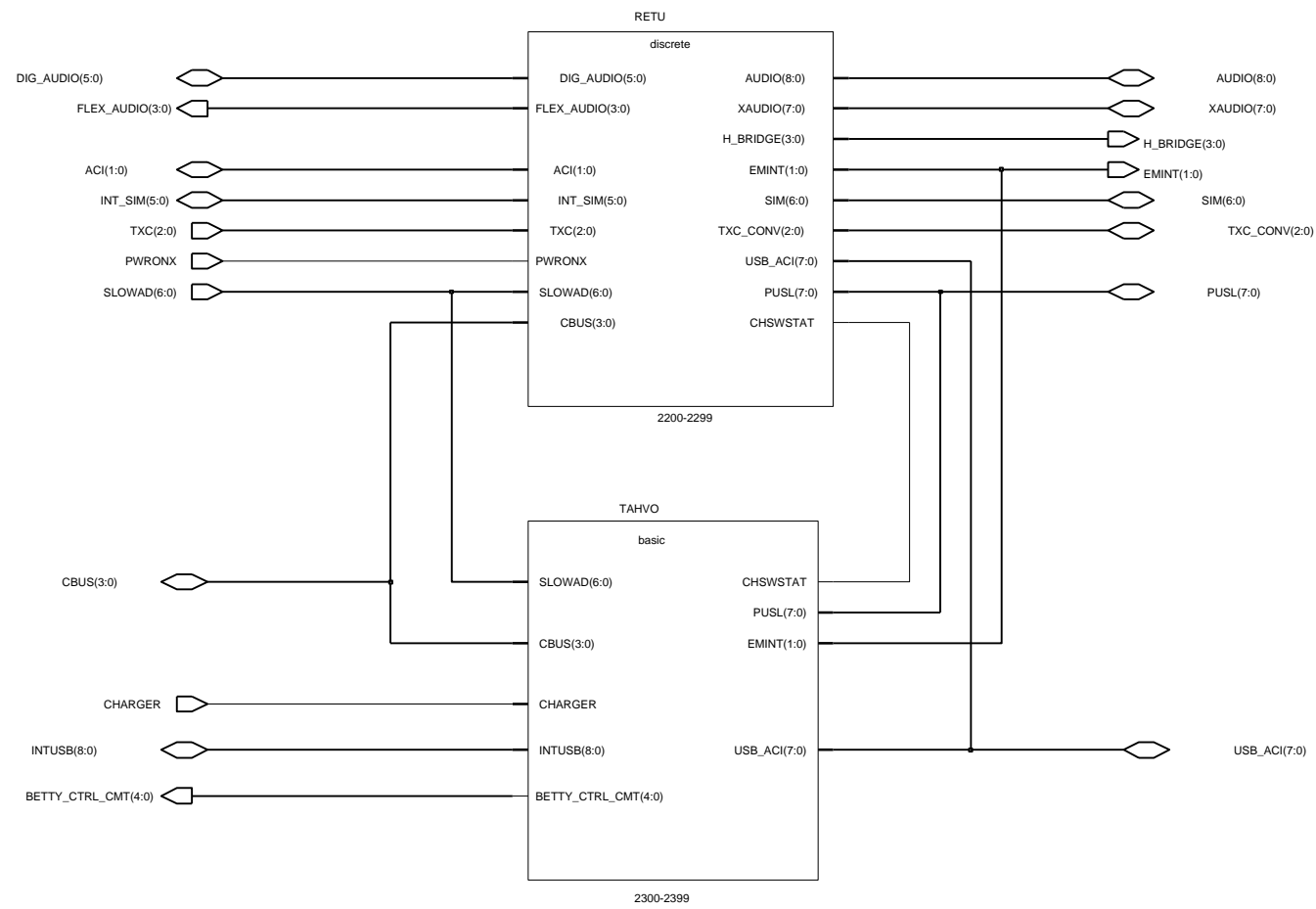

Copyright (C) Nokia Corporation. All rights reserved.
 THIS DRAWING IS PROTECTED BY COPYRIGHT AS AN UNPUBLISHED WORK.
 UNAUTHORIZED REPRODUCTION OF THIS DRAWING IS NOT PERMITTED.
 THIS DRAWING CONTAINS PROPRIETARY AND CONFIDENTIAL INFORMATION.
 This document is property of Nokia Corporation



Name	Energy management	Appr	dd-mmm-yy
Assoc	Vilbet	Des.	JARIM 26-May-04
File	/nokia/sa_nmp/groups/p3047/rm-208/1yb/1yb_07/cellular/cmt_engine/power	Dr.	TKOIVUSA 03-Jan-07
Proj	CeBBo2	Sheet	xx of yy 1 (01)
		Print	Yes v. Edit 2

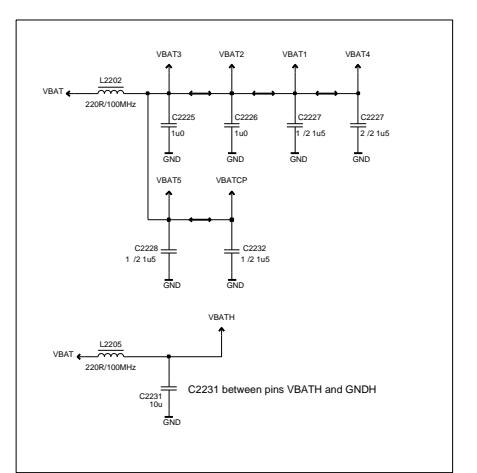
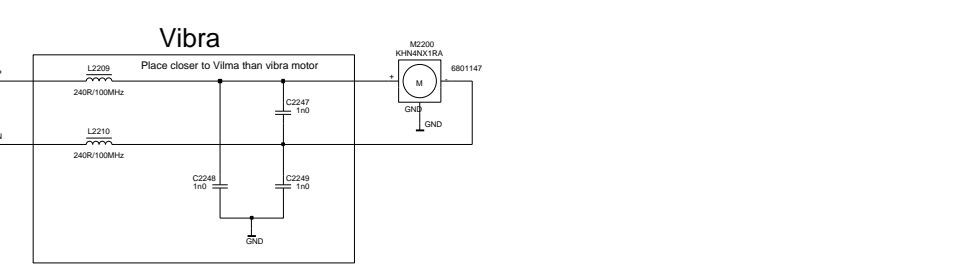
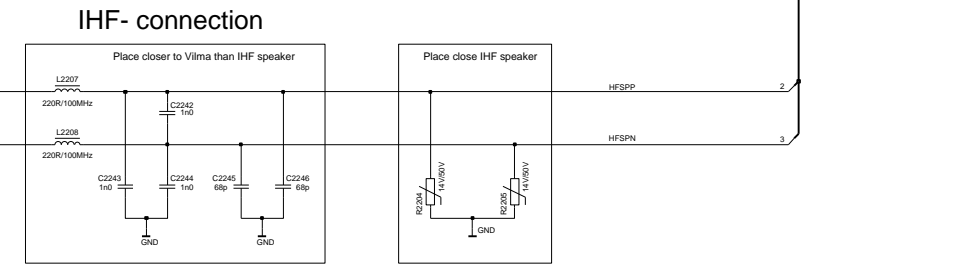
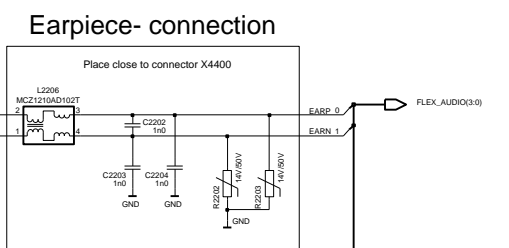
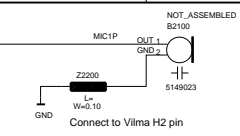
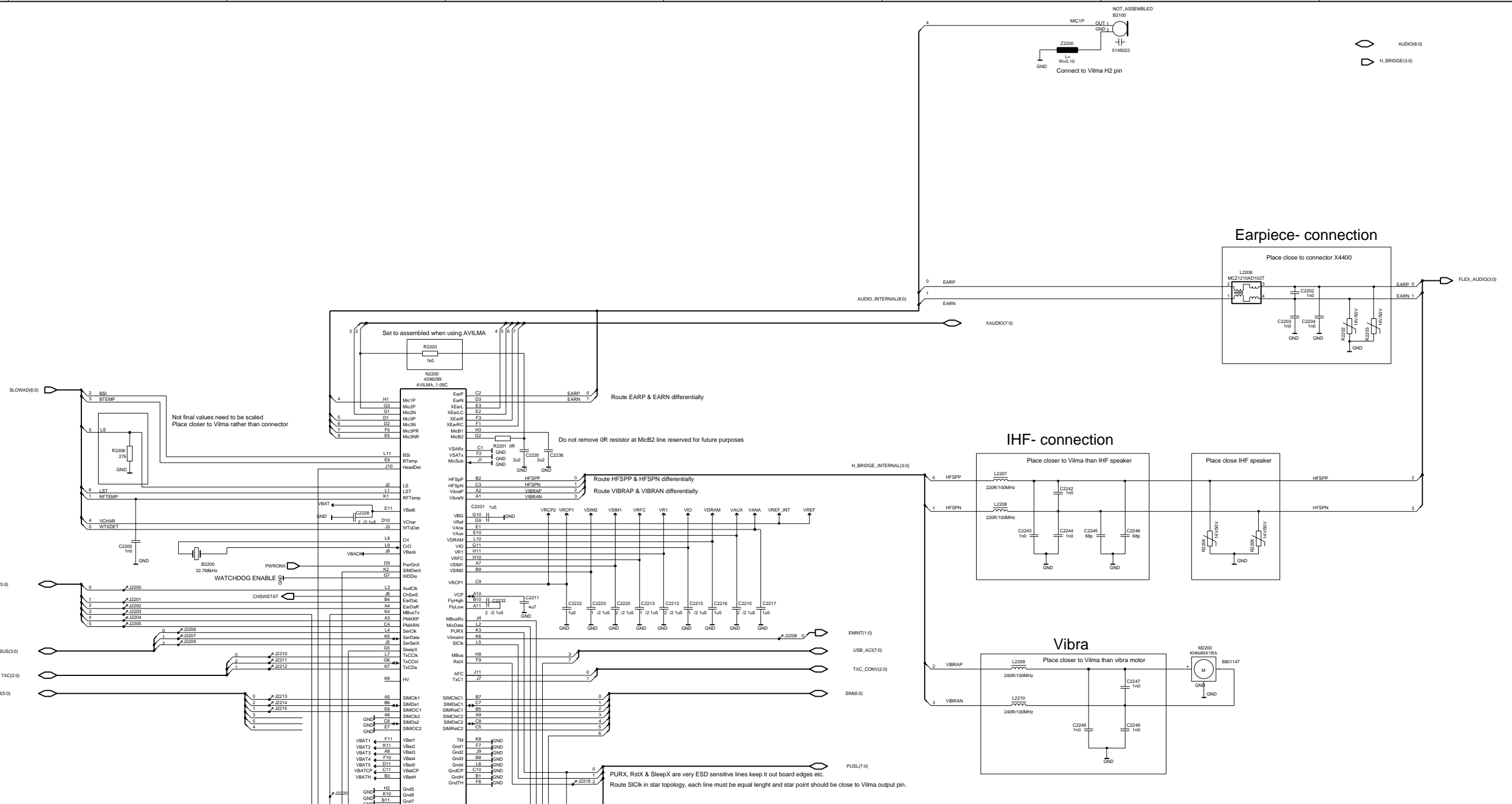

Copyright (C) Nokia Corporation. All rights reserved. THIS DRAWING IS PROTECTED BY COPYRIGHT AS AN UNPUBLISHED WORK. UNAUTHORIZED REPRODUCTION OF THIS DRAWING IS NOT PERMITTED. THIS DRAWING CONTAINS PROPRIETARY AND CONFIDENTIAL INFORMATION. This document is property of Nokia Corporation			Name	VILMA	Appr	dd-mm-yy
			Assoc	1yb	Des.	TKOI/USA
		File	/nokia/sa_nmp/groups/p3047/m-208/1yb/1yb_07/cellular/cmt_engine/power/retu	Dr.	TKOI/USA	03-Jan-07
		Proj	AFRODITE	Sheet	xx of yy	0 (01)
				Print	Yes	V. 0.0
				Edt		2

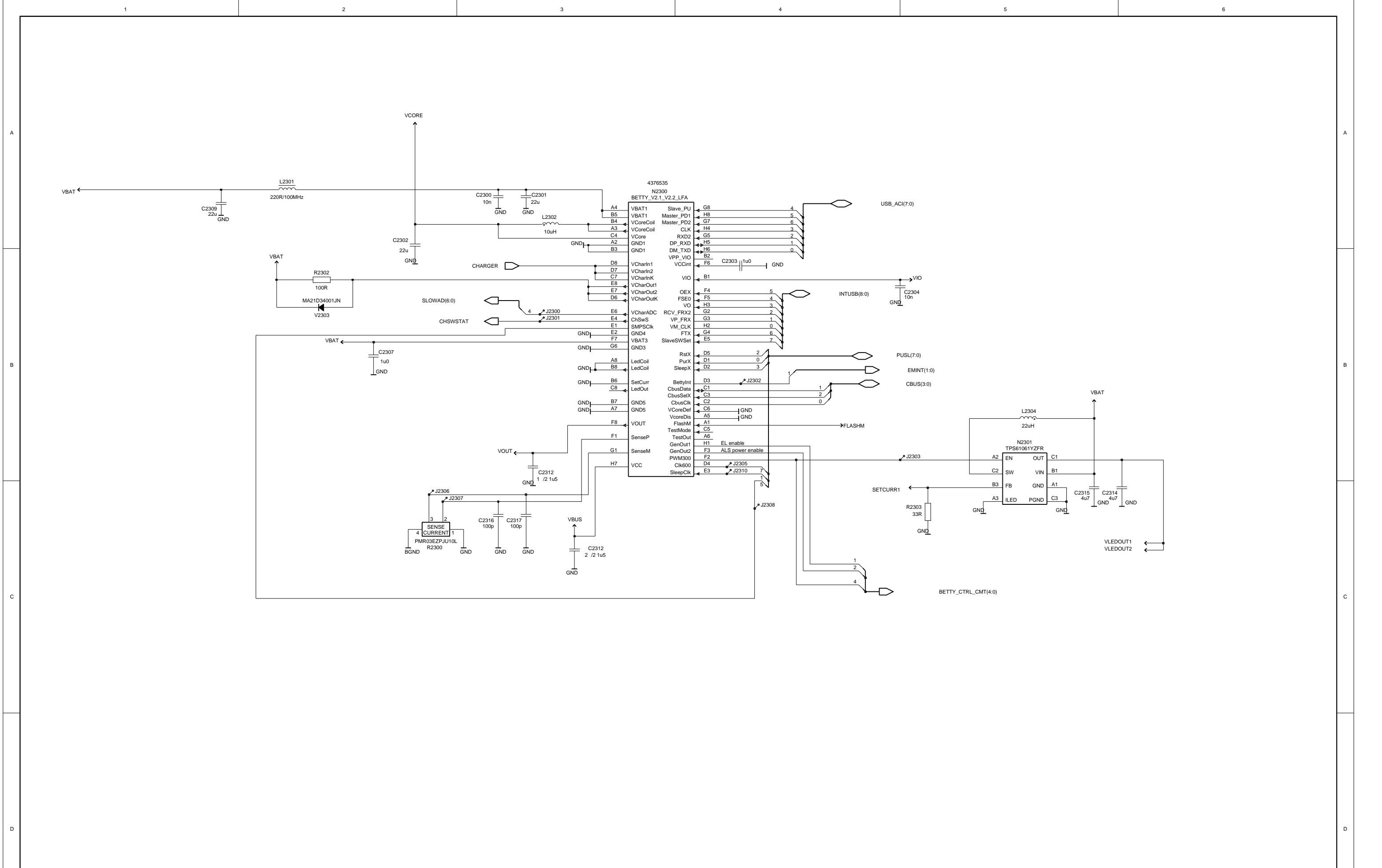

Copyright (C) Nokia Corporation. All rights reserved.
 THIS DRAWING IS PROTECTED BY COPYRIGHT AS AN UNPUBLISHED WORK.
 UNAUTHORIZED REPRODUCTION OF THIS DRAWING IS NOT PERMITTED.
 THIS DRAWING CONTAINS PROPRIETARY AND CONFIDENTIAL INFORMATION.
 This document is property of Nokia Corporation



Name	Betty	Appr	10-Aug-00
Assoc	Vilbet	Des.	JARIM 10-May-04
		Dr.	TKOIVUSA 03-Jan-07
File	/nokia/sa_nmp/groups/p3047/rm-208/1yb/1yb_07/cellular/cmt_engine/power/tahvo	Sheet	xx of yy 1 (01)
Proj	CeBBo2	Print	Yes v. Edit 2

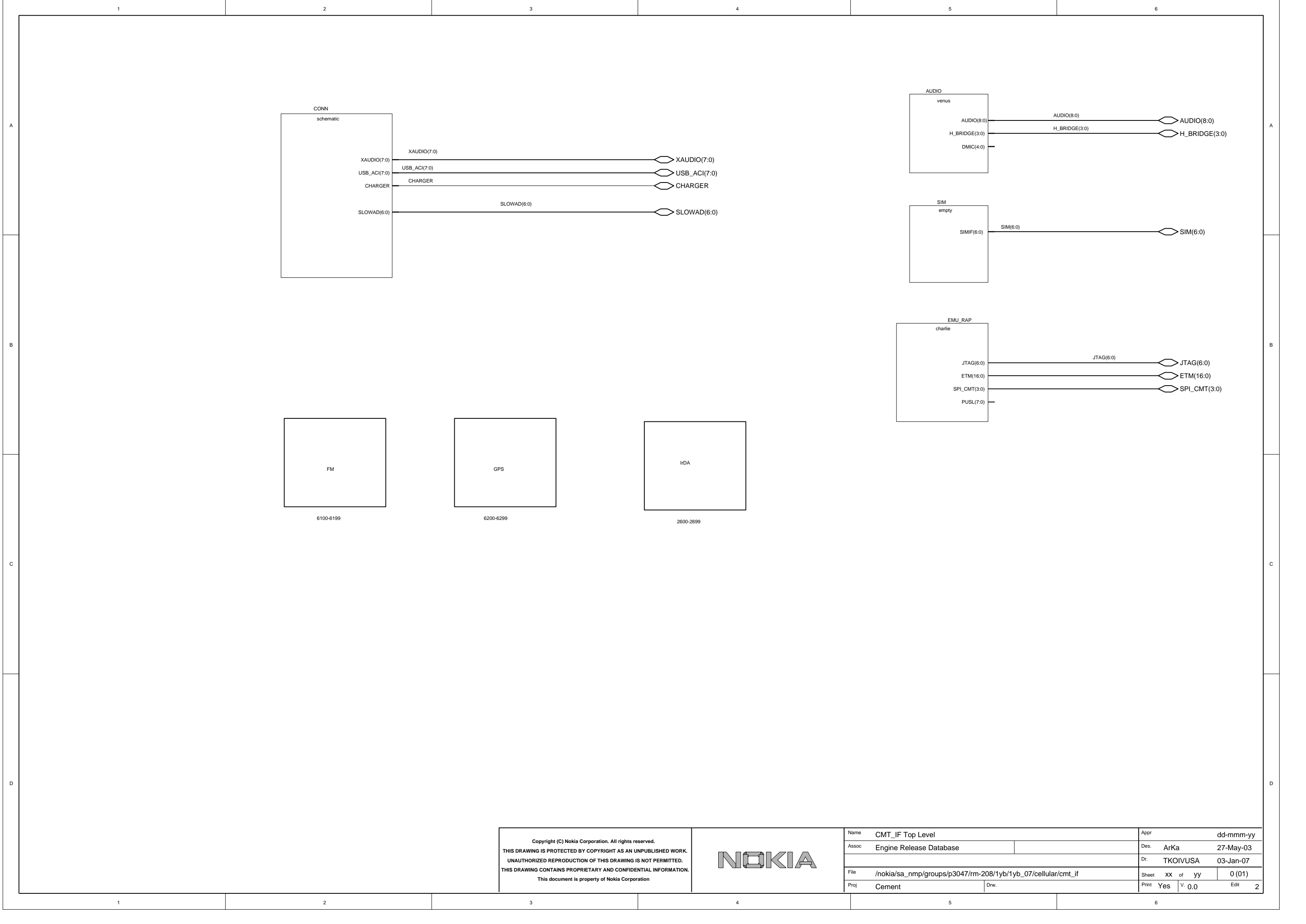

Copyright (C) Nokia Corporation. All rights reserved.
 THIS DRAWING IS PROTECTED BY COPYRIGHT AS AN UNPUBLISHED WORK.
 UNAUTHORIZED REPRODUCTION OF THIS DRAWING IS NOT PERMITTED.
 THIS DRAWING CONTAINS PROPRIETARY AND CONFIDENTIAL INFORMATION.
 This document is property of Nokia Corporation



Name	CMT_IF Top Level	Appr	dd-mmm-yy
Assoc	Engine Release Database	Des.	ArKa 27-May-03
File	/nokia/sa_nmp/groups/p3047/rm-208/1yb/1yb_07/cellular/cmt_if	Dr.	TKOIVUSA 03-Jan-07
Proj	Cement	Sheet	xx of yy 0 (01)
		Print	Yes v. 0,0 Edit 2

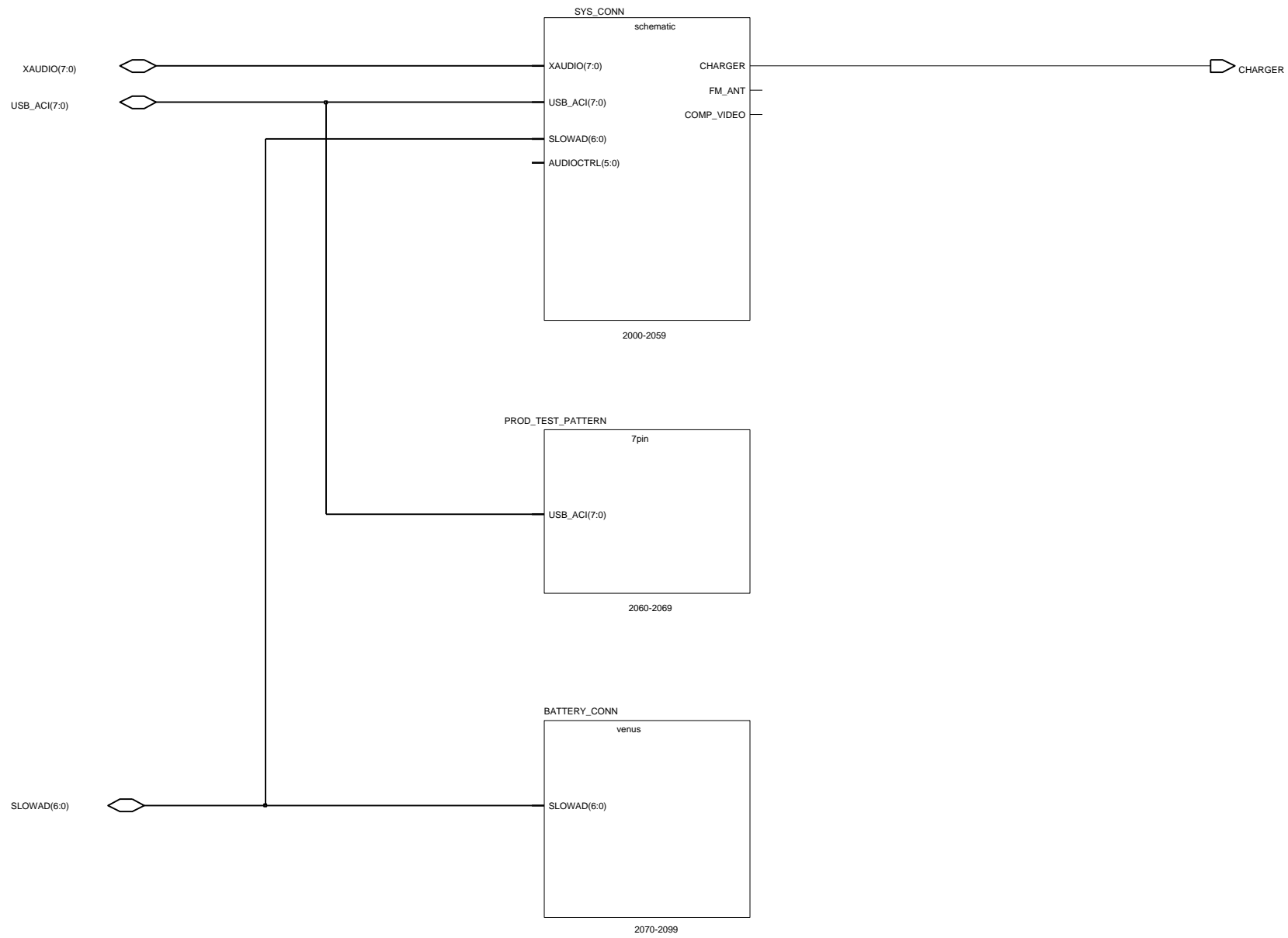

Copyright (C) Nokia Corporation. All rights reserved.
 THIS DRAWING IS PROTECTED BY COPYRIGHT AS AN UNPUBLISHED WORK.
 UNAUTHORIZED REPRODUCTION OF THIS DRAWING IS NOT PERMITTED.
 THIS DRAWING CONTAINS PROPRIETARY AND CONFIDENTIAL INFORMATION.
 This document is property of Nokia Corporation



Name	System and battery connector	Appr	10-Aug-00
Assoc	Charlie S0.6	Des.	KAYRA 18-Jan-02
		Dr.	TKOIVUSA 03-Jan-07
File	/nokia/sa_nmp/groups/p3047/rm-208/1yb/1yb_07/cellular/cmt_if/conn		Sheet xx of yy 1 (01)
Proj	CBB5X	Drw.	Print Yes v. 0,1 Edit 2

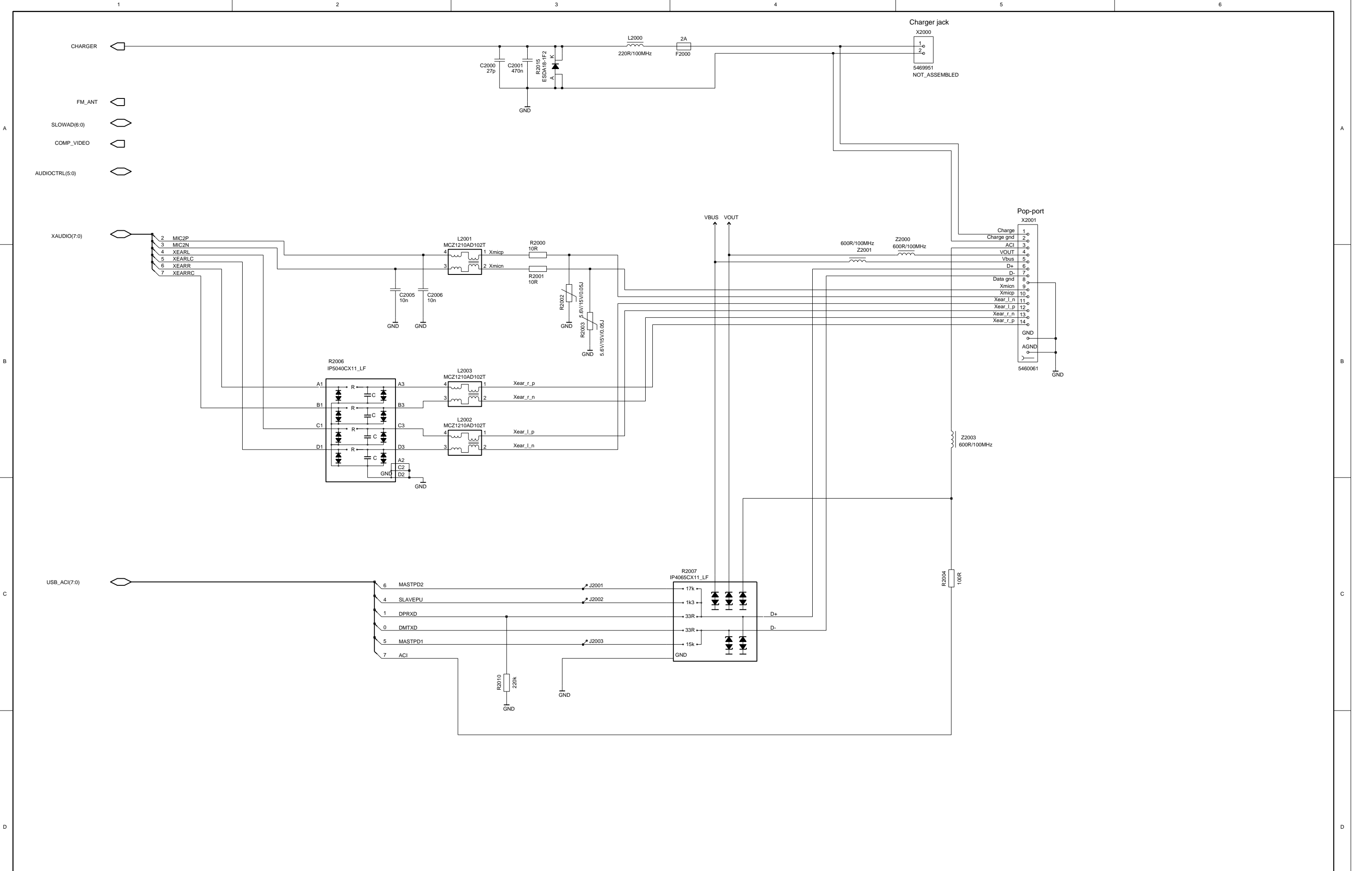

Copyright (C) Nokia Corporation. All rights reserved.
 THIS DRAWING IS PROTECTED BY COPYRIGHT AS AN UNPUBLISHED WORK.
 UNAUTHORIZED REPRODUCTION OF THIS DRAWING IS NOT PERMITTED.
 THIS DRAWING CONTAINS PROPRIETARY AND CONFIDENTIAL INFORMATION.
 This document is property of Nokia Corporation



Name	System connector	Appr	10-Aug-00
Assoc	Vilbet	Des.	JARIM 10-May-04
		Dr.	TKOIVUSA 03-Jan-07
File	/nokia/sa_nmp/groups/p3047/rm-208/1yb/1yb_07/cellular/cmt_if/sys_conn		Sheet xx of yy 1 (01)
Proj	CeBBo2	Print	Yes v. Edit 2

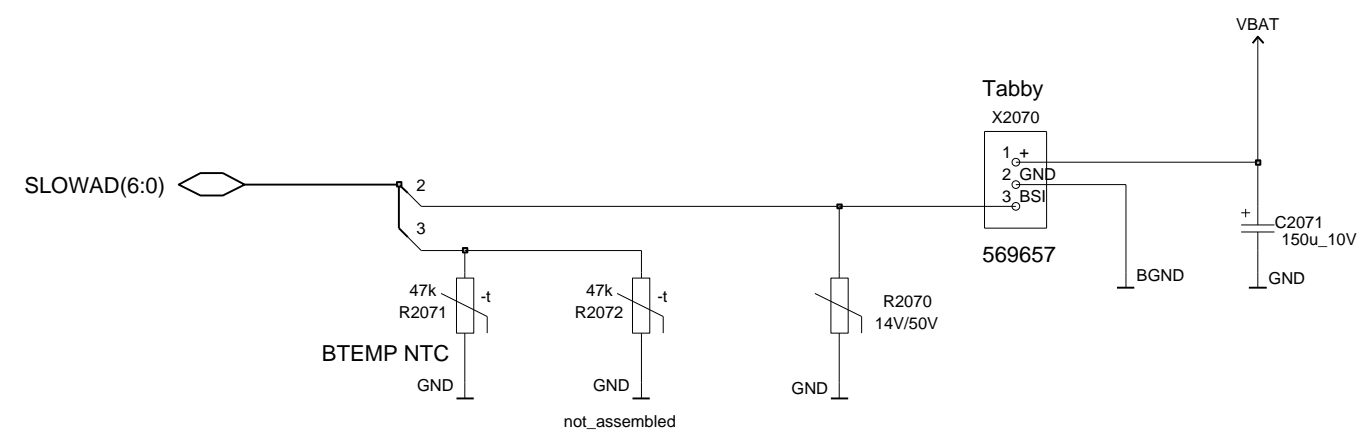

R2071 Placement is fixed according Thermal simulation. If placement need to be changed IT WILL NEED NEW SIMULATION !!!

<p>Copyright (C) Nokia Corporation. All rights reserved. THIS DRAWING IS PROTECTED BY COPYRIGHT AS AN UNPUBLISHED WORK. UNAUTHORIZED REPRODUCTION OF THIS DRAWING IS NOT PERMITTED. THIS DRAWING CONTAINS PROPRIETARY AND CONFIDENTIAL INFORMATION. This document is property of Nokia Corporation</p>		Name Battery connector		Appr dd-mmm-yy			
		Assoc		Des. elahteen 04-Nov-05			
				Dr. TKOIVUSA 03-Jan-07			
		File /nokia/sa_nmp/groups/p3047/rm-208/1yb/1yb_07/cellular/cmt_if/battery_conn		Sheet XX of yy 0 (01)			
		Proj Postman		Drw.		Print Yes V. 0.0 Edit 2	

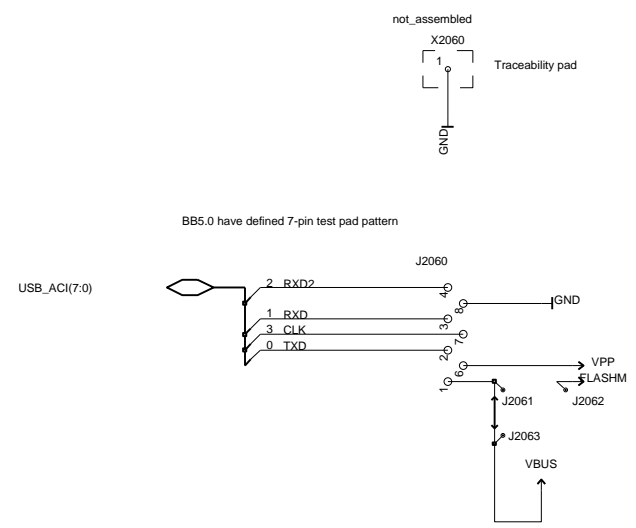

NOTE !! ABOUT VBUS & FLASHM PRODUCT SPECIFIC ISSUE !!!!
J2061-J2062 Should be placed as near as possible to each other
And signal between J2061 & J2062 Will be Left unrouted
This Way FlashM Can be Left as a backup for flashing activation

FLASHM = VBat; flashing possible
 FLASHM = floating; USB possible

Copyright (C) Nokia Corporation. All rights reserved.
 THIS DRAWING IS PROTECTED BY COPYRIGHT AS AN UNPUBLISHED WORK.
 UNAUTHORIZED REPRODUCTION OF THIS DRAWING IS NOT PERMITTED.
 THIS DRAWING CONTAINS PROPRIETARY AND CONFIDENTIAL INFORMATION.
 This document is property of Nokia Corporation



Name	Production test pad	Appr	10-Aug-00
Assoc	Charlie S0.6	Des.	KAYRA 18-Jan-02
		Dr.	TKOIVUSA 03-Jan-07
File	/nokia/sa_nmp/groups/p3047/rm-208/1yb/1yb_07/cellular/cmt_if/prod_test_pattern		Sheet xx of yy 1 (01)
Proj	CBB5X	Draw.	Print Yes v. 0,1 Edit 2

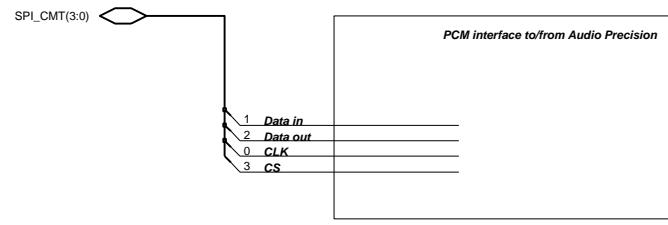
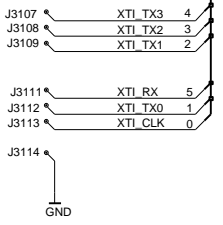
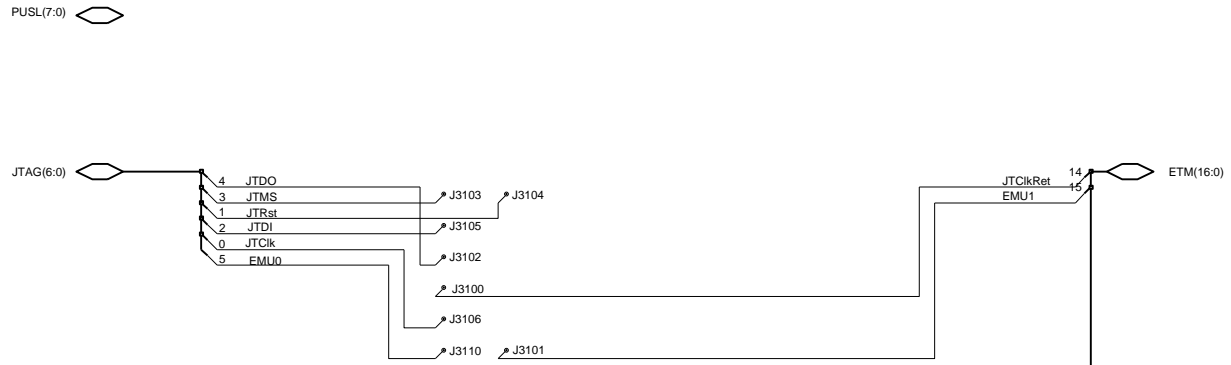

Copyright (C) Nokia Corporation. All rights reserved.
 THIS DRAWING IS PROTECTED BY COPYRIGHT AS AN UNPUBLISHED WORK.
 UNAUTHORIZED REPRODUCTION OF THIS DRAWING IS NOT PERMITTED.
 THIS DRAWING CONTAINS PROPRIETARY AND CONFIDENTIAL INFORMATION.
 This document is property of Nokia Corporation



Name	Test Interface	Appr	dd-mmm-yy
Assoc	Charlie S0.6	Des.	KAYRA 04-Jun-98
		Dr.	TKOIVUSA 03-Jan-07
File	/nokia/sa_nmp/groups/p3047/rm-208/1yb/1yb_07/cellular/cmt_if/emu_rap		Sheet xx of yy 1 (01)
Proj	CBB5X	Drw.	Print Yes V. 1.3 Edit 2

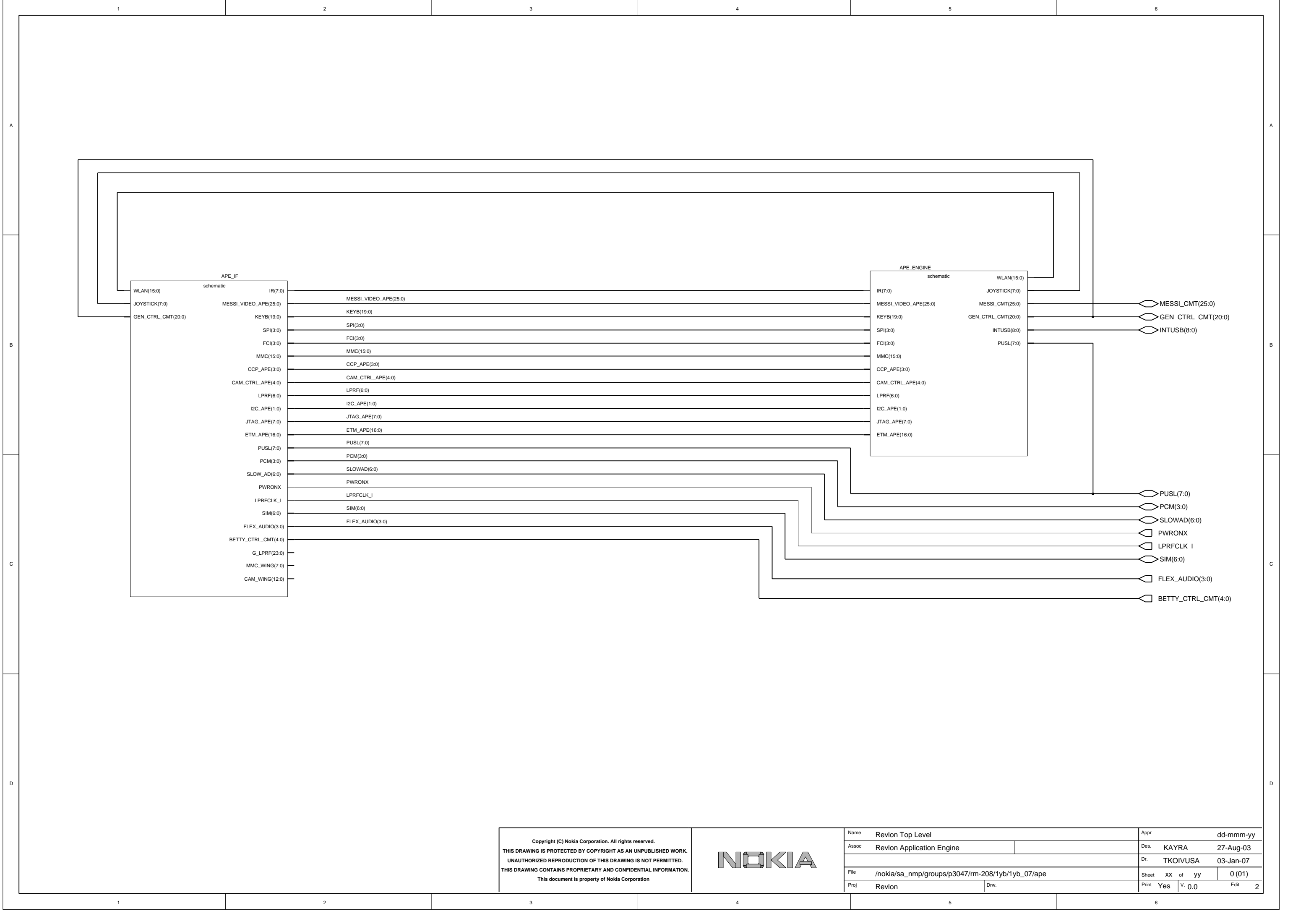

Copyright (C) Nokia Corporation. All rights reserved.
 THIS DRAWING IS PROTECTED BY COPYRIGHT AS AN UNPUBLISHED WORK.
 UNAUTHORIZED REPRODUCTION OF THIS DRAWING IS NOT PERMITTED.
 THIS DRAWING CONTAINS PROPRIETARY AND CONFIDENTIAL INFORMATION.
 This document is property of Nokia Corporation



Name	Revlon Top Level	Appr	dd-mmm-yy
Assoc	Revlon Application Engine	Des.	KAYRA 27-Aug-03
File	/nokia/sa_nmp/groups/p3047/rm-208/1yb/1yb_07/ape	Dr.	TKOIVUSA 03-Jan-07
Proj	Revlon	Sheet	xx of yy 0 (01)
		Print	Yes v. 0.0 Edit 2

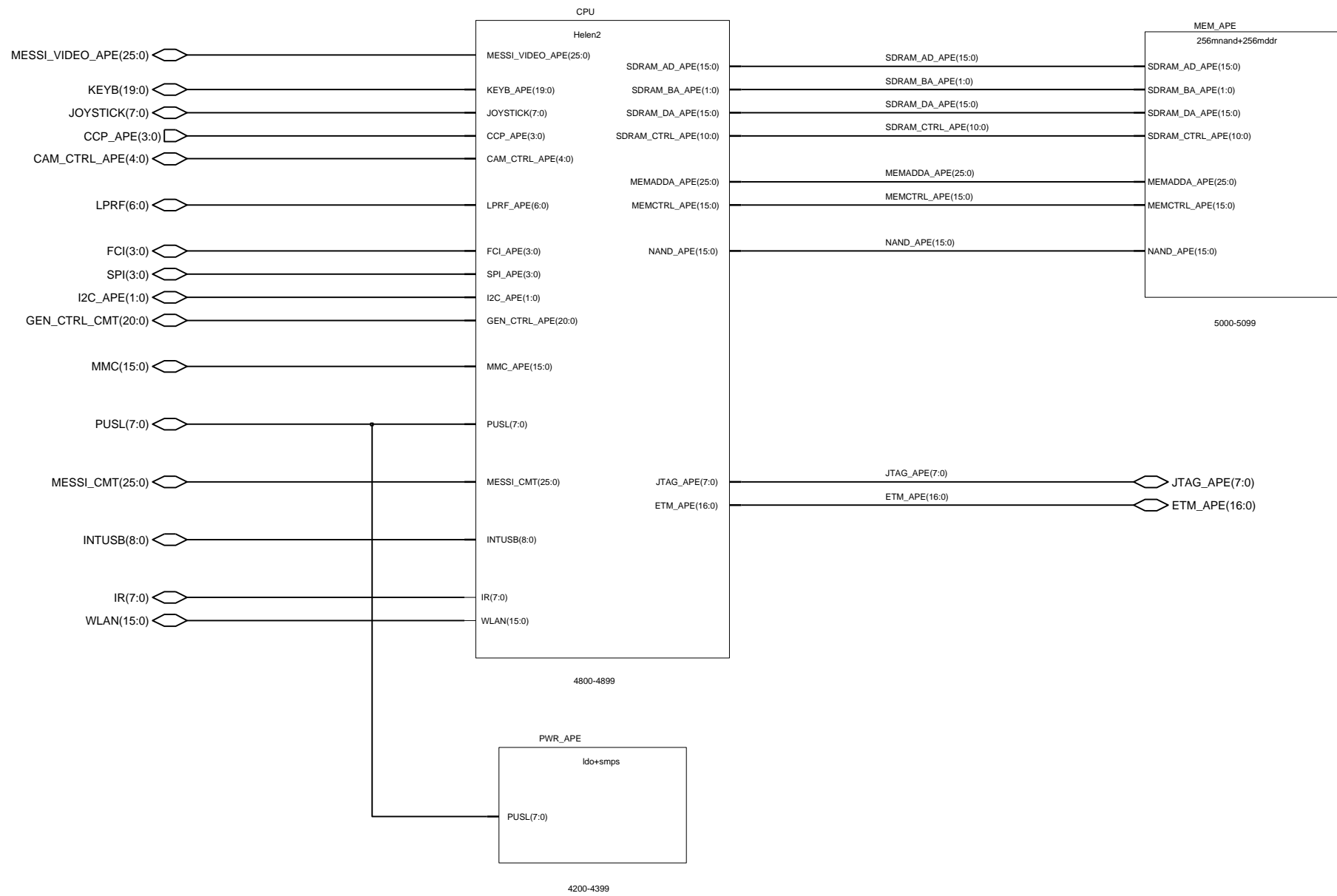

Copyright (C) Nokia Corporation. All rights reserved.
 THIS DRAWING IS PROTECTED BY COPYRIGHT AS AN UNPUBLISHED WORK.
 UNAUTHORIZED REPRODUCTION OF THIS DRAWING IS NOT PERMITTED.
 THIS DRAWING CONTAINS PROPRIETARY AND CONFIDENTIAL INFORMATION.
 This document is property of Nokia Corporation



Name	Ape Engine	Appr	dd-mmm-yy
Assoc	Revlon Application Engine	Des.	KAYRA 27-Aug-03
		Dr.	TKOIVUSA 03-Jan-07
File	/nokia/sa_nmp/groups/p3047/rm-208/1yb/1yb_07/ape/ape_engine		Sheet xx of yy 0 (01)
Proj	Revlon	Draw.	Print Yes v. 0.0 Edit 2

A

B

C

D

A

B

C

D

MEMADDA_APE(25:0)

MEMCTRL_APE(15:0)

SDRAM_AD_APE(15:0)

SDRAM_CTRL_APE(10:0)

SDRAM_BA_APE(1:0)

NAND_APE(15:0)

SDRAM_DA_APE(15:0)

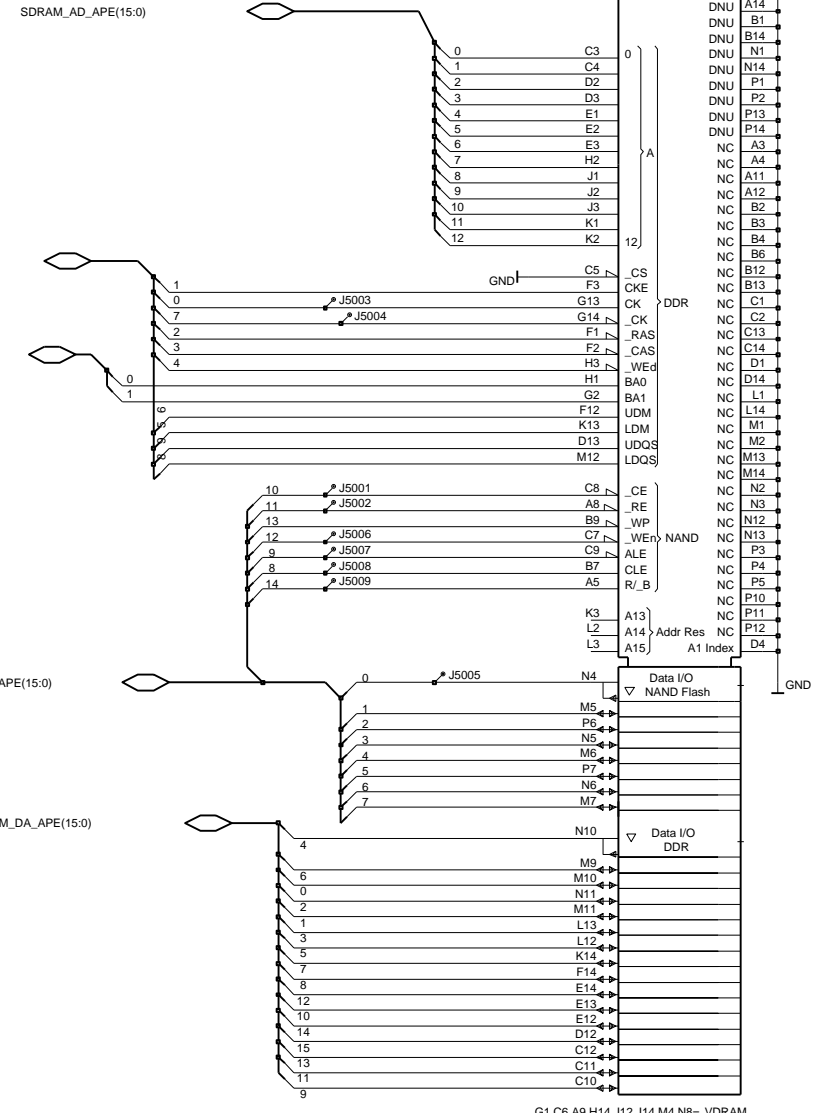

G1,C6,A9,H14,J12,J14,M4,N8= VDRAM
 B11,M8,H13,J13= VIO
 A6= VIO
 N7= VIO
 B5,B10,G3,G12,H12,M3,N9= GND
 A10,F13,K12,P9= GND
 A7,B8,P8= GND

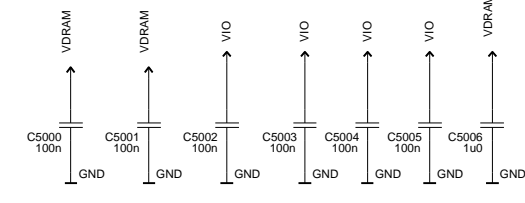

Copyright (C) Nokia Corporation. All rights reserved.
 THIS DRAWING IS PROTECTED BY COPYRIGHT AS AN UNPUBLISHED WORK.
 UNAUTHORIZED REPRODUCTION OF THIS DRAWING IS NOT PERMITTED.
 THIS DRAWING CONTAINS PROPRIETARY AND CONFIDENTIAL INFORMATION.
 This document is property of Nokia Corporation



Name	APE Memories	Appr	10-Aug-00
Assoc	Charlie S0.6	Des.	KAYRA 11-Apr-2001
File	/nokia/sa_nmp/groups/p3047/rm-208/1yb/1yb_07/ape/ape_engine/mem_ape	Dr.	TKOIVUSA 03-Jan-07
Proj	CBB5X	Sheet	xx of yy 1 (01)
		Print	Yes v. 0,1 Edit 2

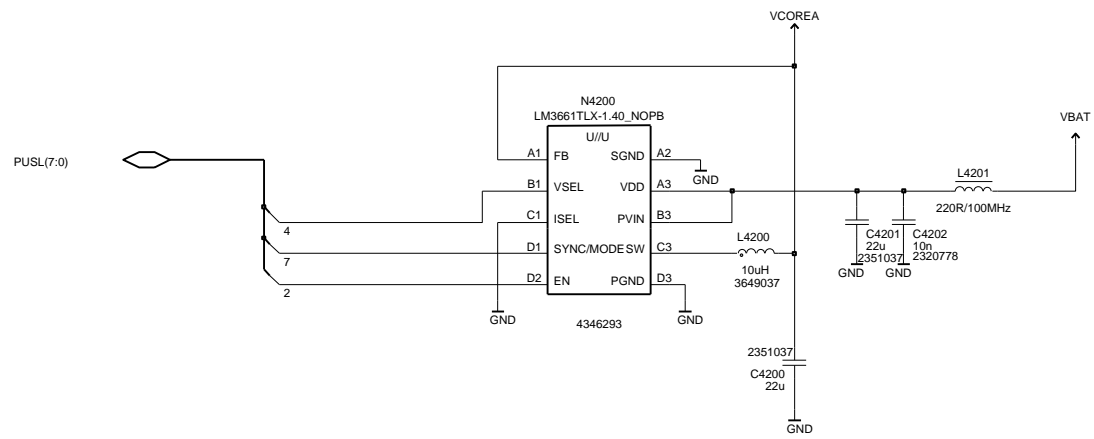

Copyright (C) Nokia Corporation. All rights reserved.
 THIS DRAWING IS PROTECTED BY COPYRIGHT AS AN UNPUBLISHED WORK.
 UNAUTHORIZED REPRODUCTION OF THIS DRAWING IS NOT PERMITTED.
 THIS DRAWING CONTAINS PROPRIETARY AND CONFIDENTIAL INFORMATION.
 This document is property of Nokia Corporation



Name	Discrete regulators	Appr	10-Aug-00
Assoc	Charlie S0.6	Des.	KAYRA 15-Jan-03
		Dr.	TKOIVUSA 03-Jan-07
File	/nokia/sa_nmp/groups/p3047/rm-208/1yb/1yb_07/ape/ape_engine/pwr_ape		Sheet xx of yy 1 (00)
Proj	CBB5X	Drw.	Print Yes V. 0,1 Edit 2

See Helen2_3 uses cases before remapping pins
 Not pin compatible with Helen3 (OMAP1710)

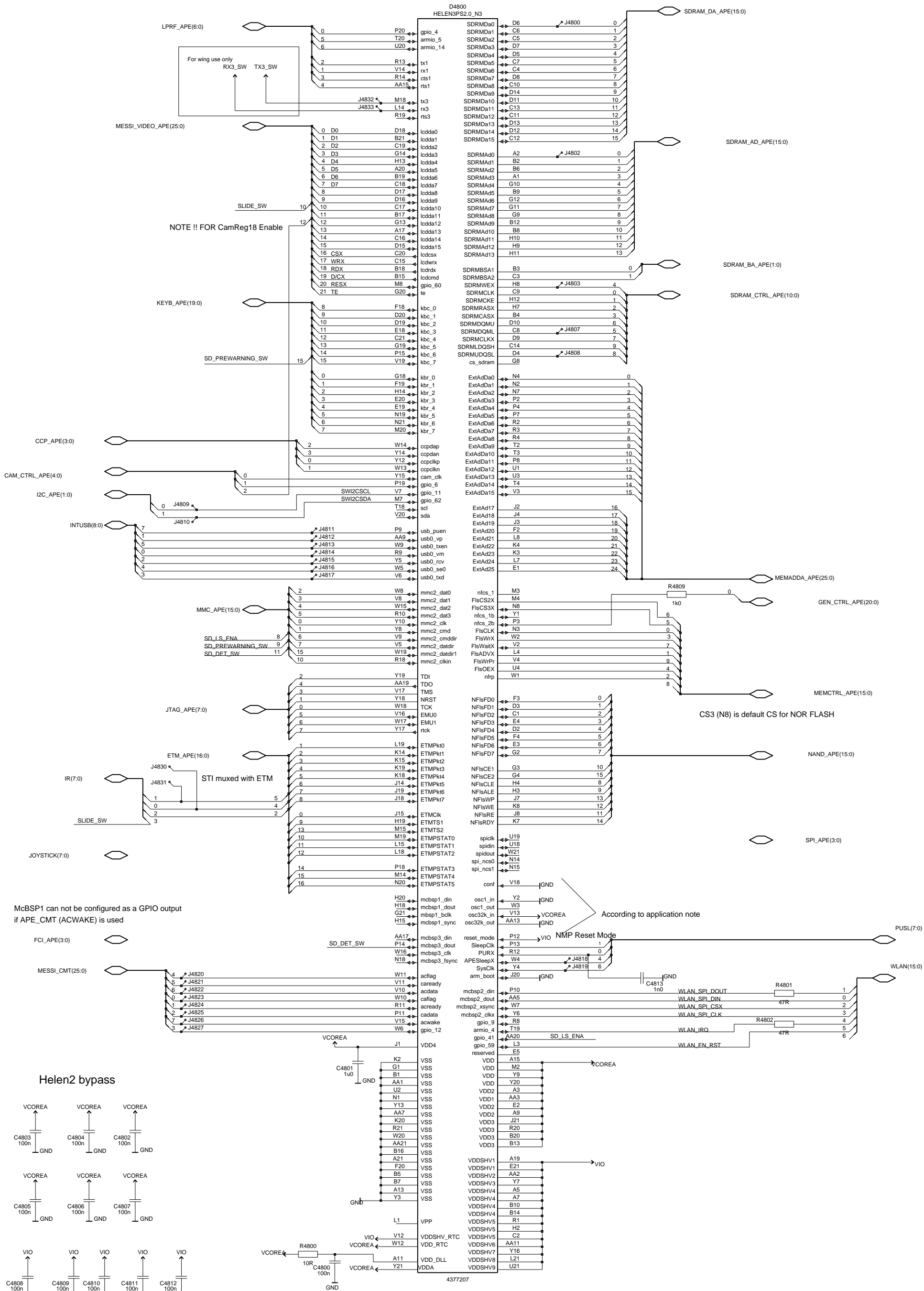

Copyright (C) Nokia Corporation. All rights reserved.
 THIS DRAWING IS PROTECTED BY COPYRIGHT AS AN UNPUBLISHED WORK.
 UNAUTHORIZED REPRODUCTION OF THIS DRAWING IS NOT PERMITTED.
 THIS DRAWING CONTAINS PROPRIETARY AND CONFIDENTIAL INFORMATION.
 This document is property of Nokia Corporation



Name	Helen2	Appr	dd-mmm-yy
Assoc	1yb	Des.	KAYRA 27-Aug-03
		Tech	Revlon
		Dr.	TKOIVUSA 03-Jan-07
File	/nokia/sa_nmp/groups/p3047/rm-208/1yb/1yb_07/ape/ape_engine/cpu	Sheet	xx of yy 1 (01)
Proj	AFRODITE	Print	Yes V. 02 Edit 2

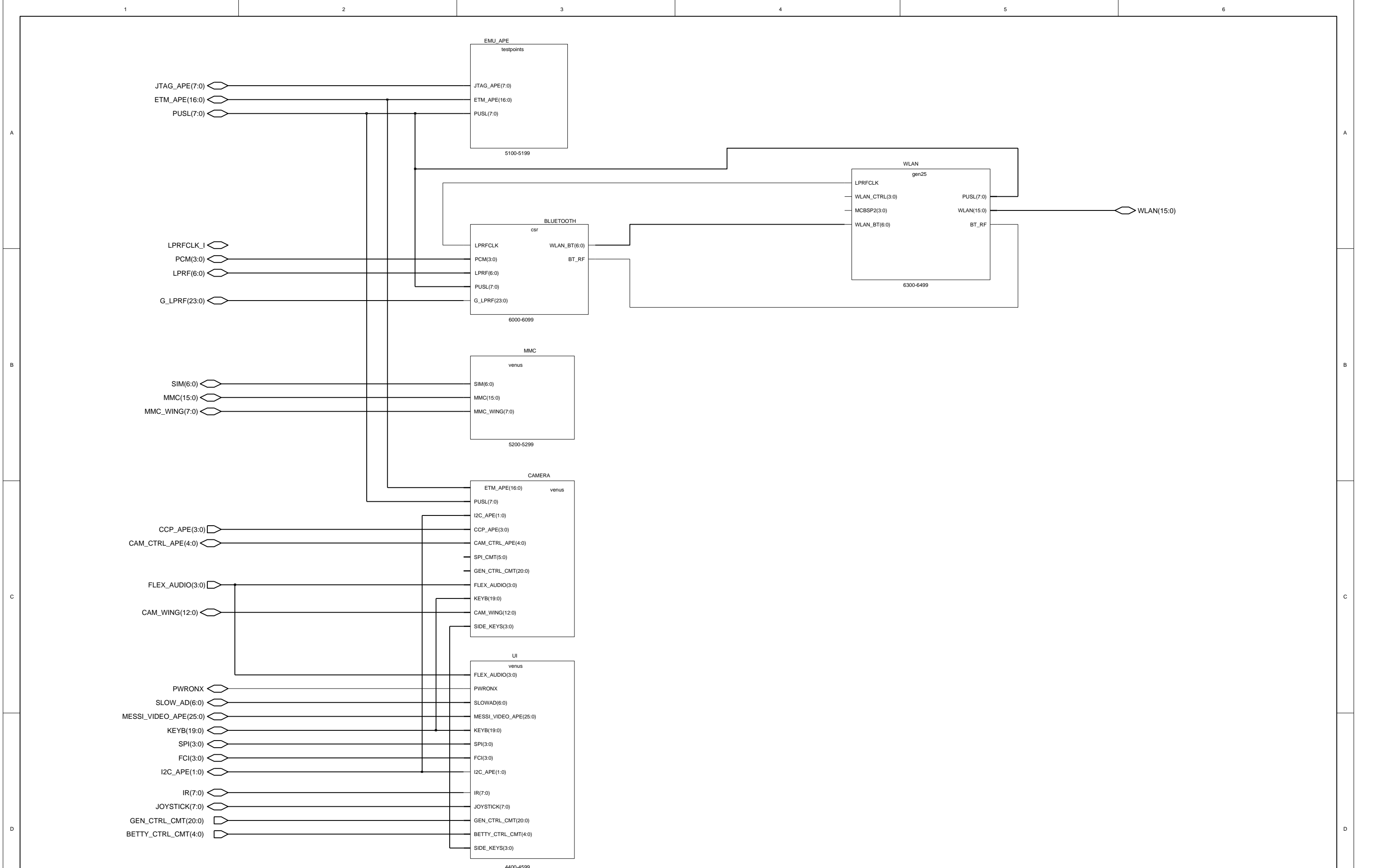

Copyright (C) Nokia Corporation. All rights reserved.
 THIS DRAWING IS PROTECTED BY COPYRIGHT AS AN UNPUBLISHED WORK.
 UNAUTHORIZED REPRODUCTION OF THIS DRAWING IS NOT PERMITTED.
 THIS DRAWING CONTAINS PROPRIETARY AND CONFIDENTIAL INFORMATION.
 This document is property of Nokia Corporation



Name	Appr	dd-mmm-yy
Assoc	Des.	27-May-03
	Dr.	TKOIVUSA 03-Jan-07
File	Sheet xx of yy	01
Proj	Print Yes	V. 0,0 Edit 2

STV984

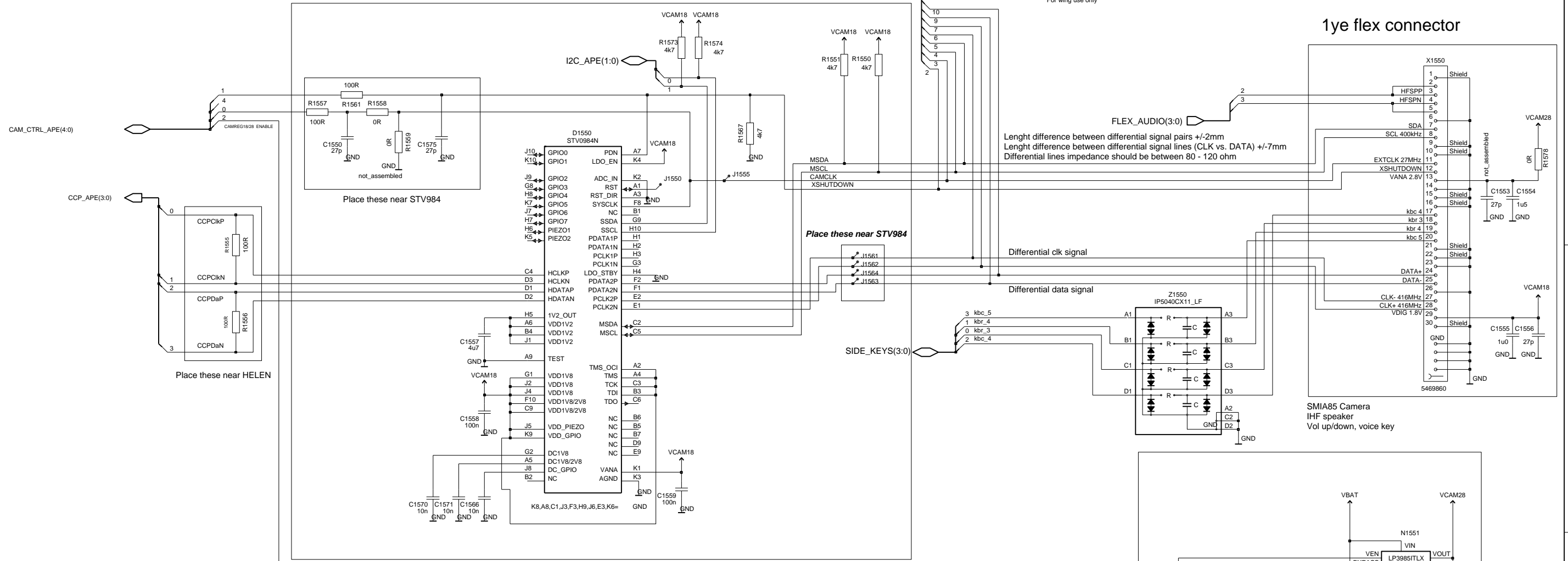

- KEYB(19:0)
- ETM_APE(16:0)
- PUSL(7:0)
- GEN_CTRL_CMT(20:0)
- SPL_CMT(5:0)

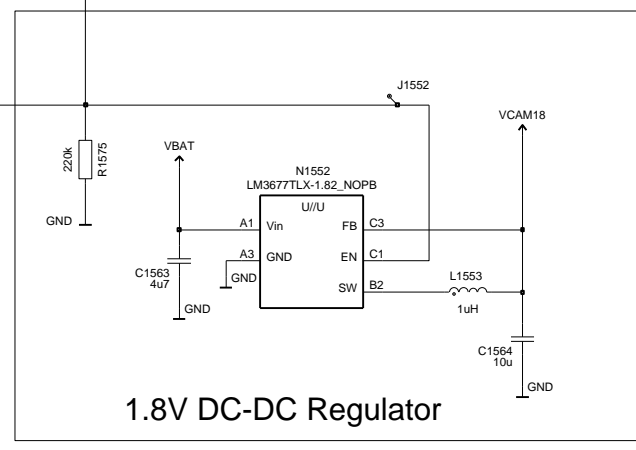
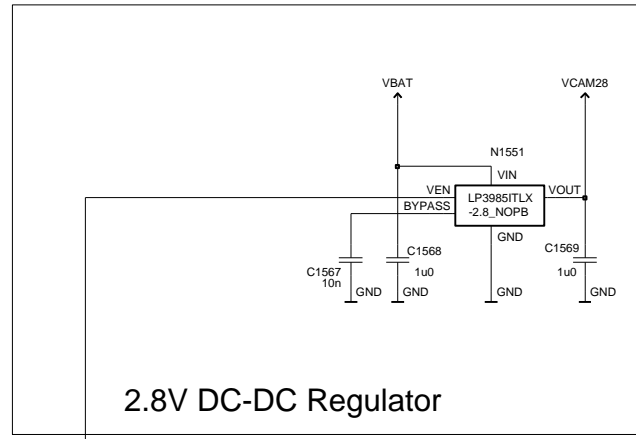

Copyright (C) Nokia Corporation. All rights reserved.
 THIS DRAWING IS PROTECTED BY COPYRIGHT AS AN UNPUBLISHED WORK.
 UNAUTHORIZED REPRODUCTION OF THIS DRAWING IS NOT PERMITTED.
 THIS DRAWING CONTAINS PROPRIETARY AND CONFIDENTIAL INFORMATION.
 This document is property of Nokia Corporation



Name	STV984+SMA85	Appr	dd-mmm-yy
Assoc	1yb	Des.	elahteen 04-Nov-05
File	/nokia/sa_nmp/groups/p3047/rm-208/1yb/1yb_07/ape/ape_if/camera	Dr.	TKOIVUSA 03-Jan-07
Proj	AFRODITE	Sheet	xx of yy 0 (01)
Draw.		Print	Yes v. 0.0 Edit 3

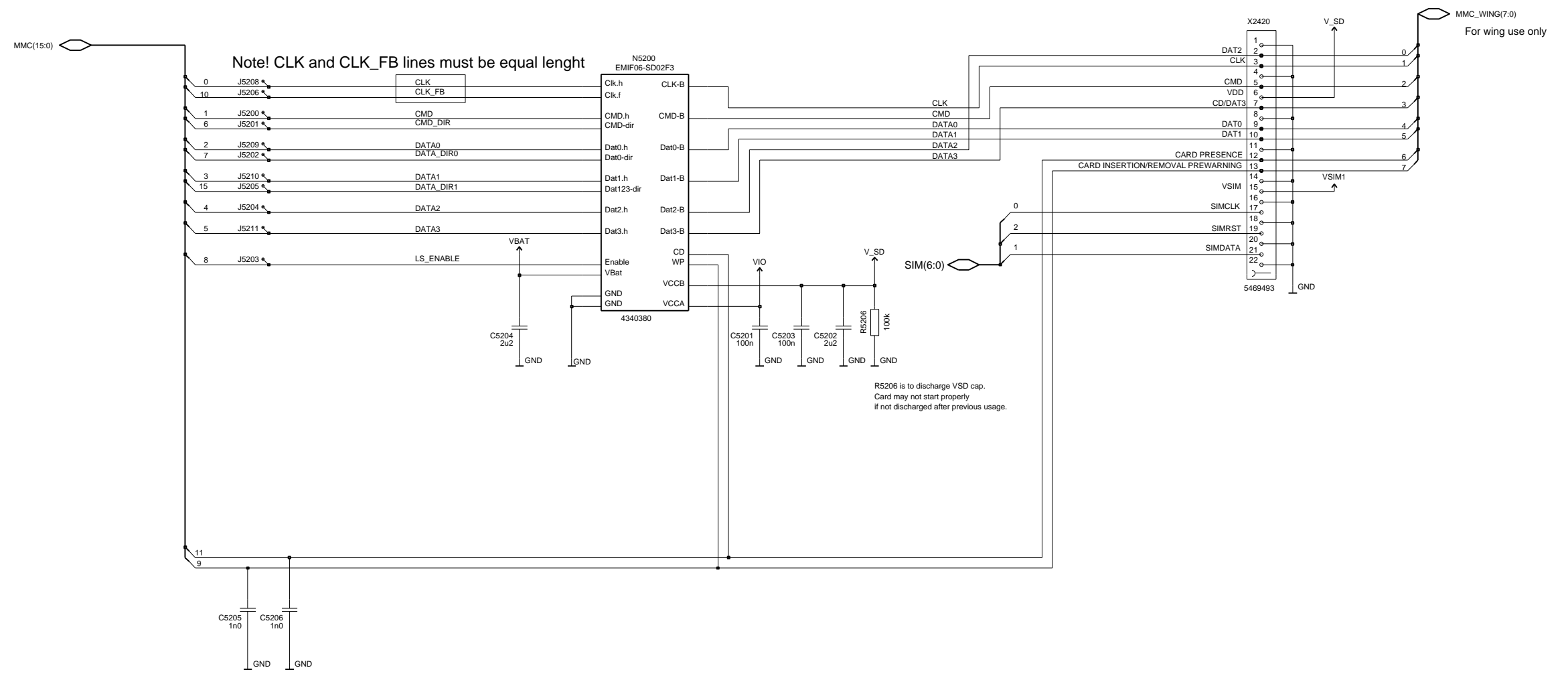

Copyright (C) Nokia Corporation. All rights reserved.
 THIS DRAWING IS PROTECTED BY COPYRIGHT AS AN UNPUBLISHED WORK.
 UNAUTHORIZED REPRODUCTION OF THIS DRAWING IS NOT PERMITTED.
 THIS DRAWING CONTAINS PROPRIETARY AND CONFIDENTIAL INFORMATION.
 This document is property of Nokia Corporation



Name	MMC	Appr	dd-mmm-yy
Assoc	1ax	Des.	KAYRA 11-Apr-2001
		Tech	Revlon
File	/nokia/sa_nmp/groups/p3047/rm-208/1yb/1yb_07/ape/ape_if/mmc		Sheet xx of yy 1 (01)
Proj	CHARLIE	Drw.	Print Yes v. 02 Edit 3

JOYSTICK(7:0)

I2C_APE(1:0)

SPI(3:0)

FC(3:0)

MESSI_VIDEO_APE(25:0)

Module has 33kOhm internal resistor in enable line together with R4402 they will limit enable current.
 Small current => EL lamp will discharge slowly => a bit dimmer lamp and less audible noise
 Enable current must be between 10 - 50uA, with 82k external resistor current will be 27.8 - 36.5uA
 (VBAT varying between 3.2 - 4.2V)

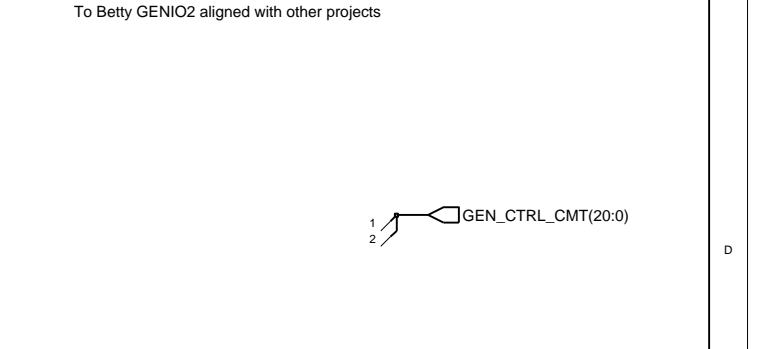
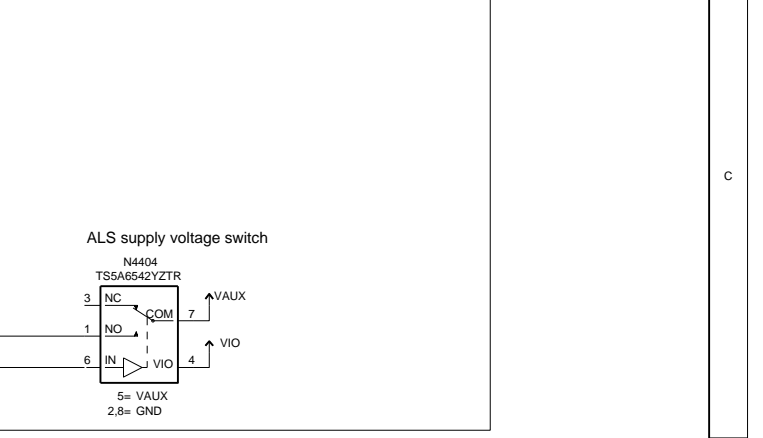
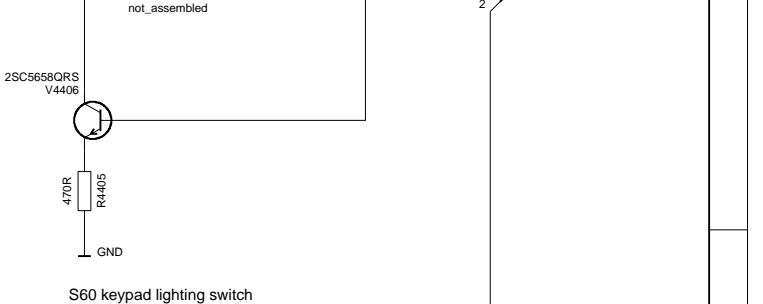
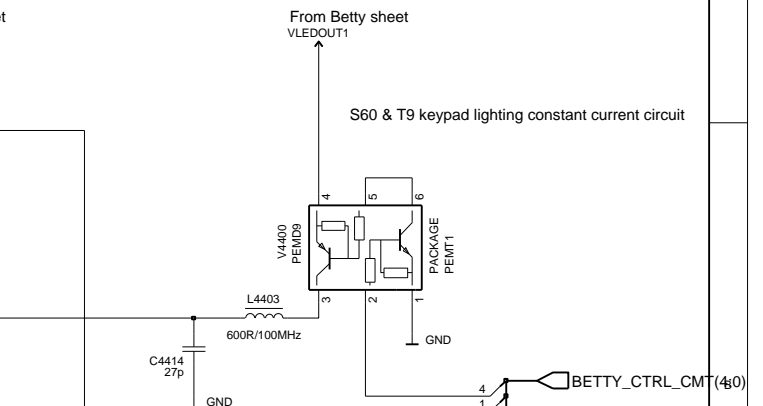
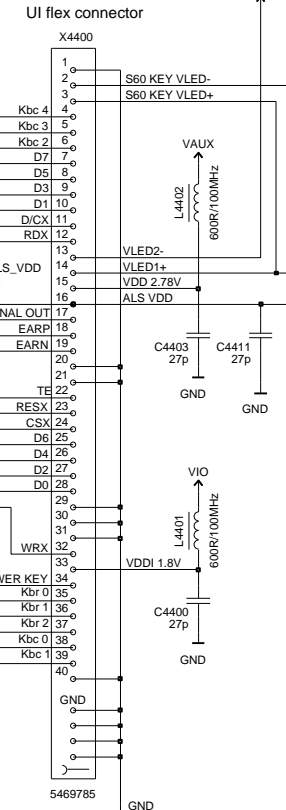
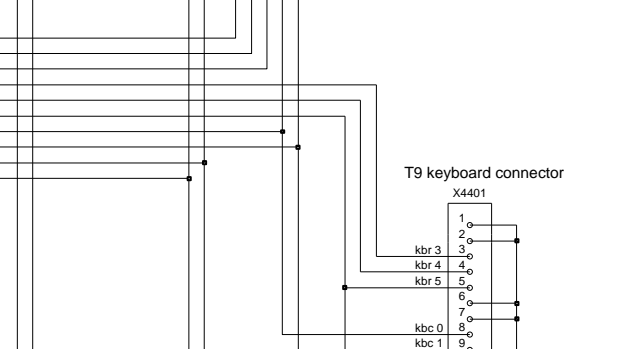
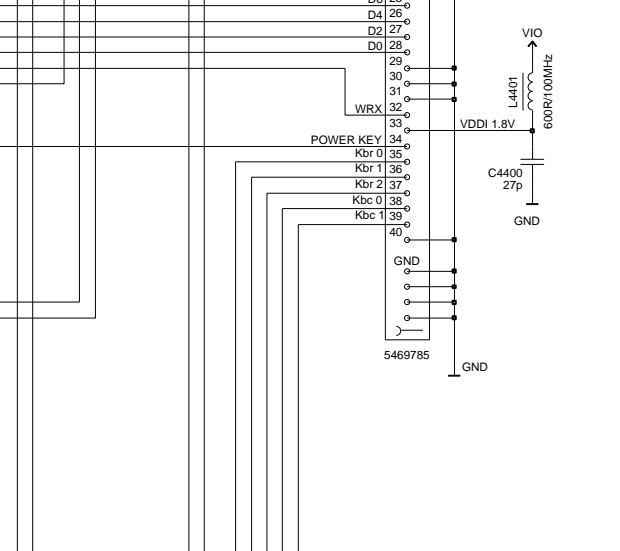
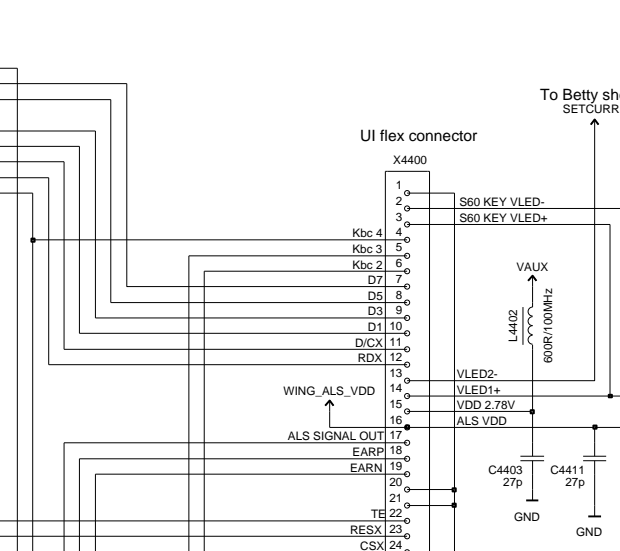
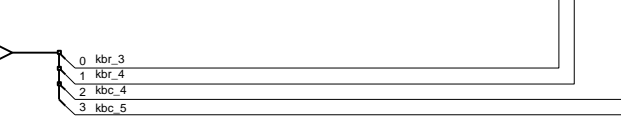
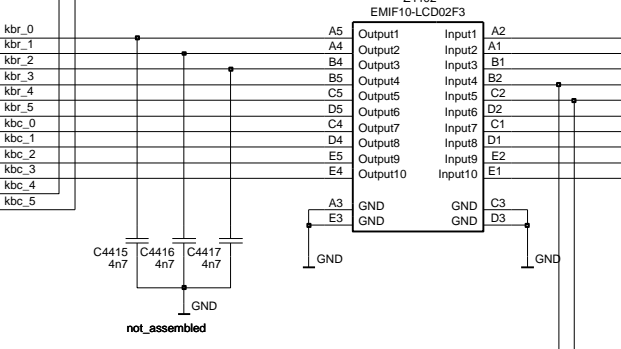
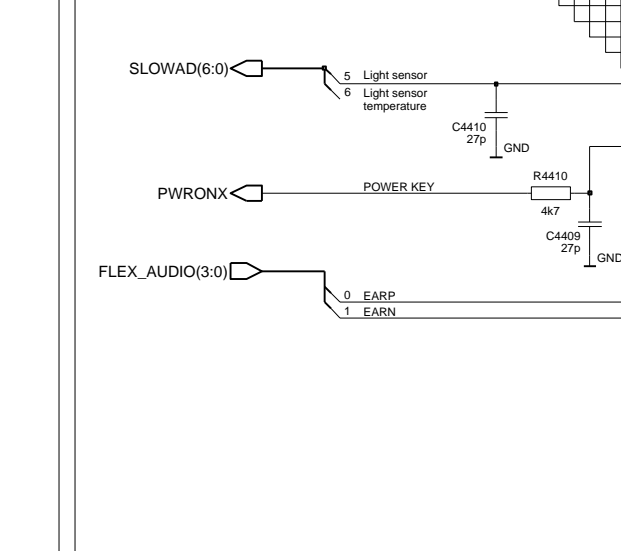
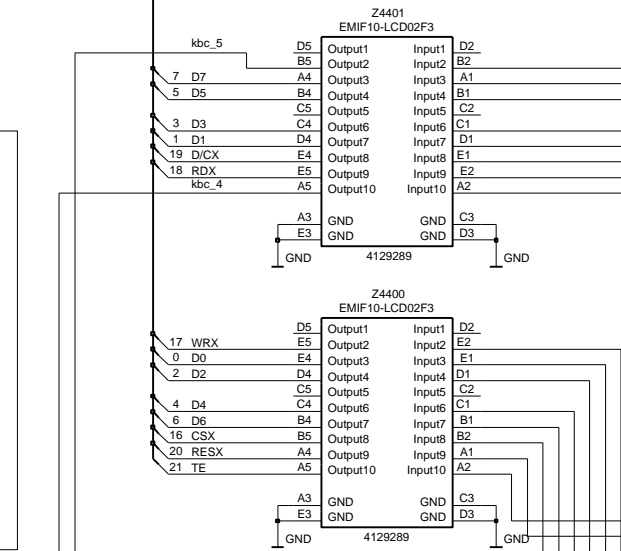
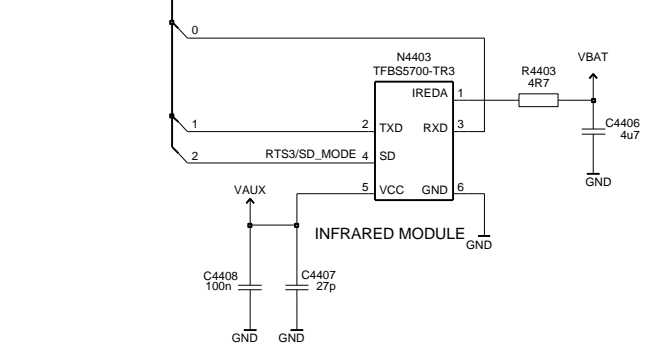
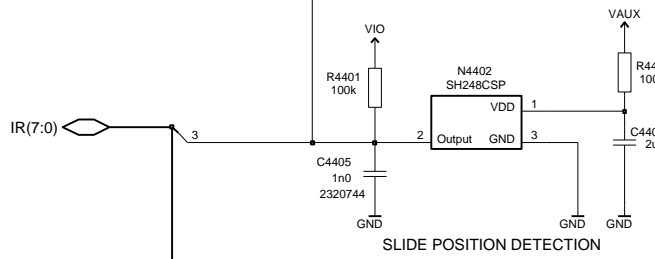
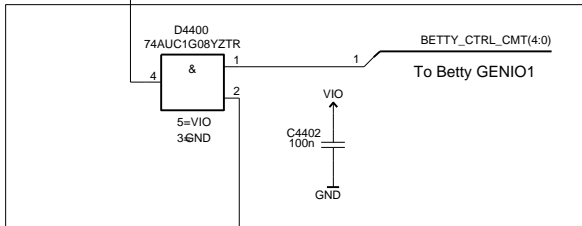
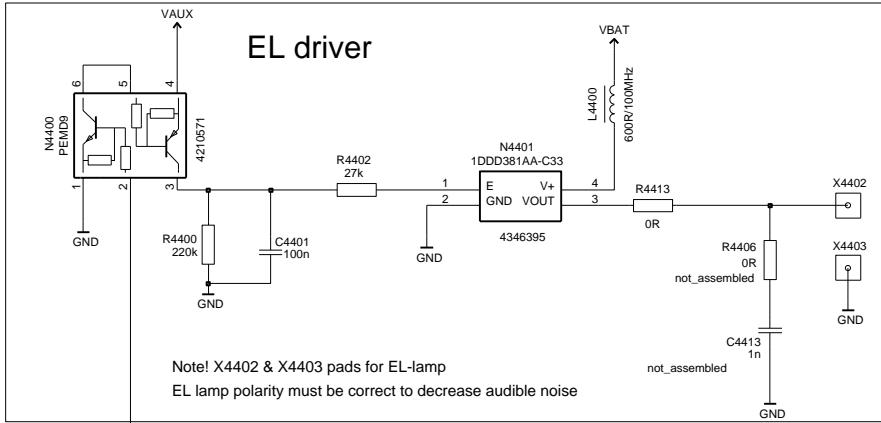

Copyright (C) Nokia Corporation. All rights reserved.
 THIS DRAWING IS PROTECTED BY COPYRIGHT AS AN UNPUBLISHED WORK.
 UNAUTHORIZED REPRODUCTION OF THIS DRAWING IS NOT PERMITTED.
 THIS DRAWING CONTAINS PROPRIETARY AND CONFIDENTIAL INFORMATION.
 This document is property of Nokia Corporation



Name	UI	Appr	dd-mmm-yy
Assoc	1yb	Des.	15-Jan-03
		Tech	Revlon
		Dr.	TKOIVUSA 03-Jan-07
File	/nokia/sa_nmp/groups/p3047/rm-208/1yb/1yb_07/ape/ape_if/ui		Sheet xx of yy 0 (01)
Proj	AFRODITE	Print	Yes v. 02 Edit 2

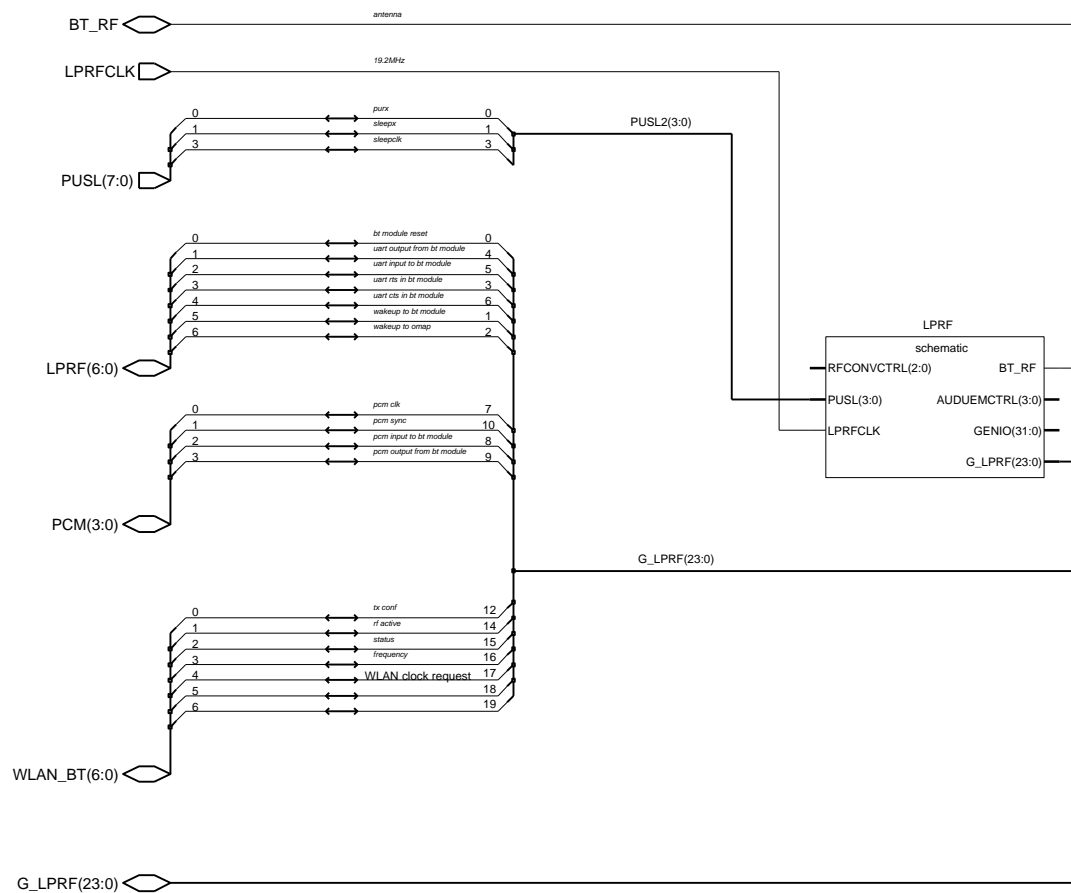

Copyright (C) Nokia Corporation. All rights reserved.
 THIS DRAWING IS PROTECTED BY COPYRIGHT AS AN UNPUBLISHED WORK.
 UNAUTHORIZED REPRODUCTION OF THIS DRAWING IS NOT PERMITTED.
 THIS DRAWING CONTAINS PROPRIETARY AND CONFIDENTIAL INFORMATION.
 This document is property of Nokia Corporation



Name	CSR Bluetooth Interface	Appr	dd-mmm-yy
Assoc		Des.	KAYRA 29-Aug-03
	Tech BlueBird	Dr.	TKOIVUSA 03-Jan-07
File	/nokia/sa_nmp/groups/p3047/rm-208/1yb/1yb_07/ape/ape_if/bluetooth	Sheet	xx of yy 0 (01)
Proj	Drw.	Print	Yes v. 02 Edit 2

BTHCOST_3.0 (TI NON-BUFF)

BLUETOOTH CIRCUIT

- RFCONVCTRL(2:0)
- AUDUEMCTRL(3:0)
- GENIO(31:0)

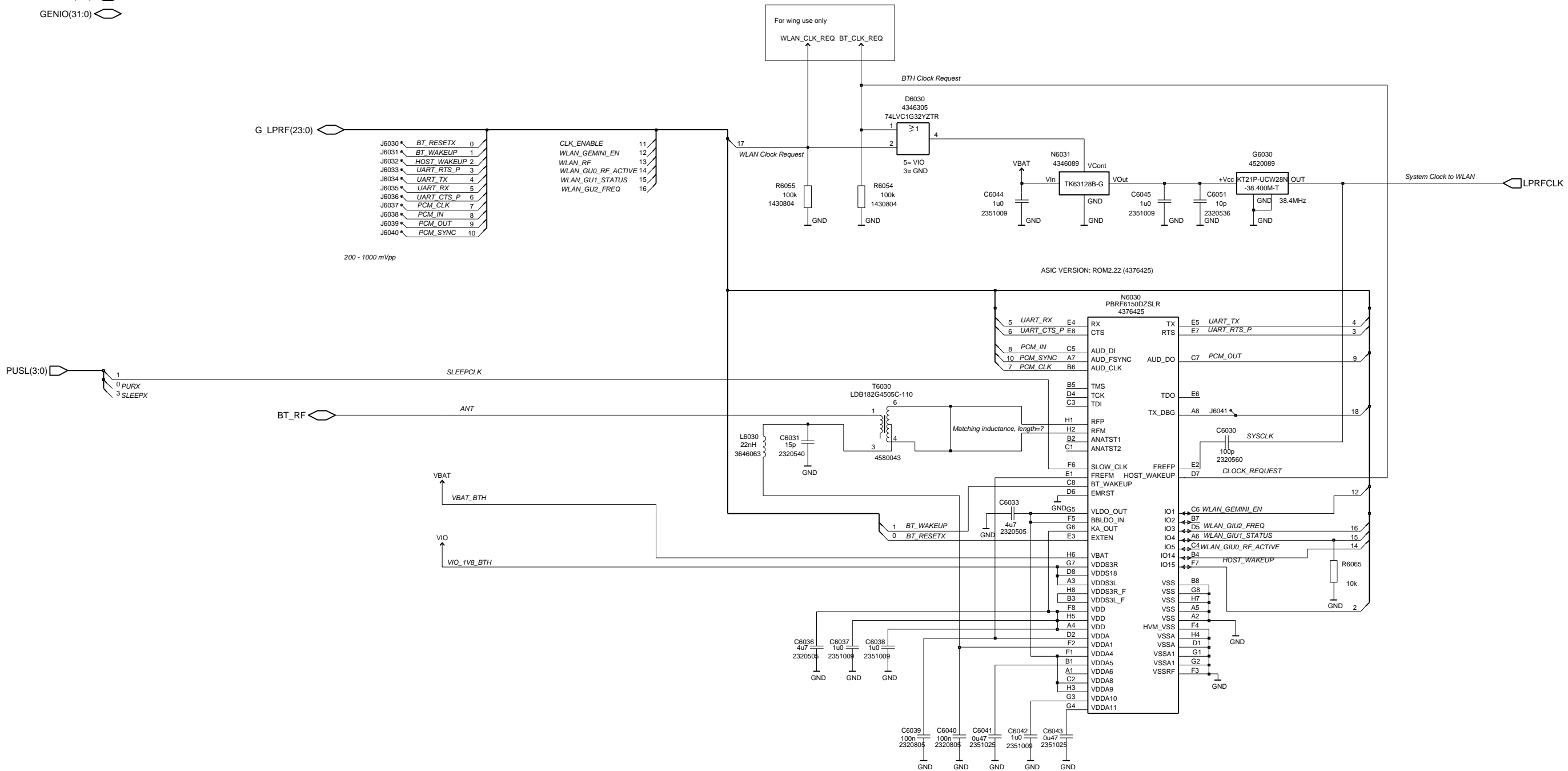

Name	BTHCOST 3.0	Appr	dd-mmm-yy
Assoc		Des.	TI 13-Feb-06
File	/nokia/sa_nmp/groups/p3047/rm-208/1yb/1yb_hw/ape/ape_if/lprf	Dr.	STA 29-Aug-06
Proj	AFRODITE	Sheet	xx of yy 0 (01)
Draw.		Print	Yes v. 0.0 Edit 25

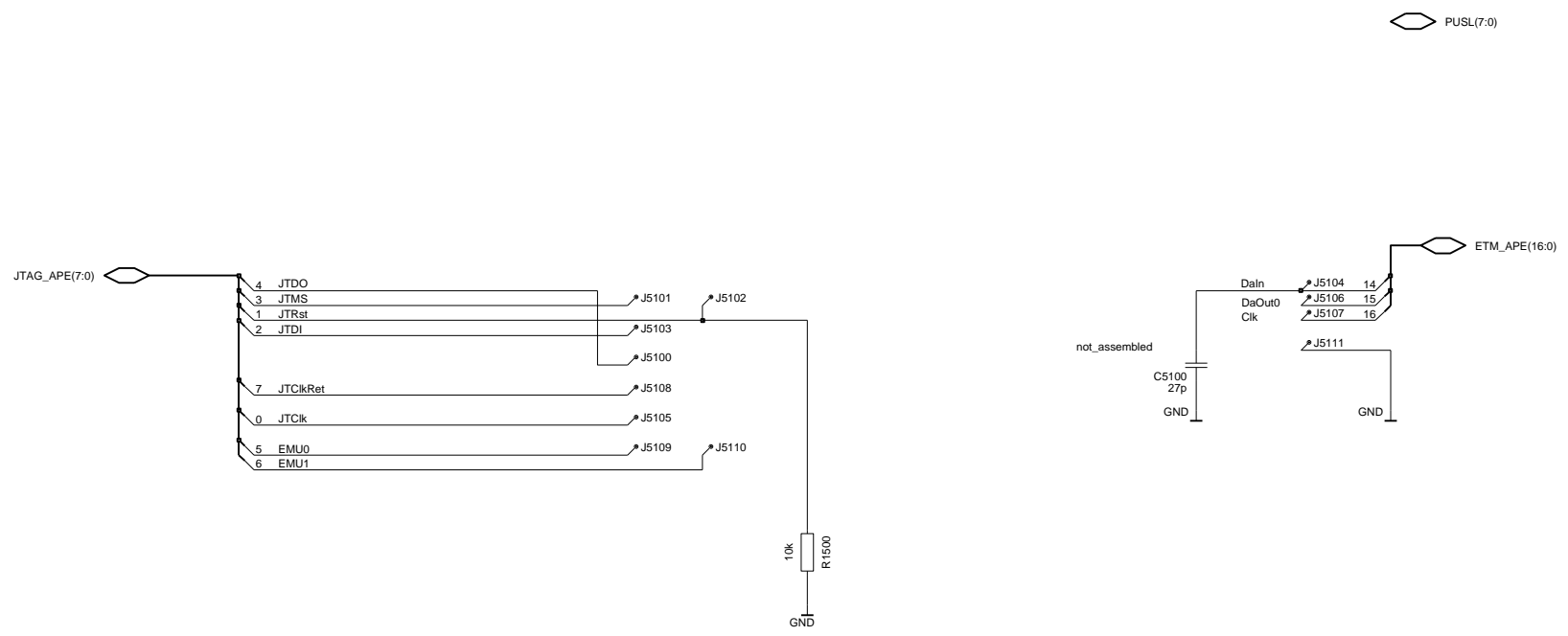

Copyright (C) Nokia Corporation. All rights reserved.
 THIS DRAWING IS PROTECTED BY COPYRIGHT AS AN UNPUBLISHED WORK.
 UNAUTHORIZED REPRODUCTION OF THIS DRAWING IS NOT PERMITTED.
 THIS DRAWING CONTAINS PROPRIETARY AND CONFIDENTIAL INFORMATION.
 This document is property of Nokia Corporation



Name	JTAG + ETM	Appr	dd-mmm-yy
Assoc	1yb	Des.	ILJARVIN 29-Aug-03
		Dr.	TKOIVUSA 03-Jan-07
File	/nokia/sa_nmp/groups/p3047/rm-208/1yb/1yb_07/ape/ape_if/emu_ape		Sheet xx of yy 1 (01)
Proj	AFRODITE	Drw.	Print Yes v. 02 Edit 2

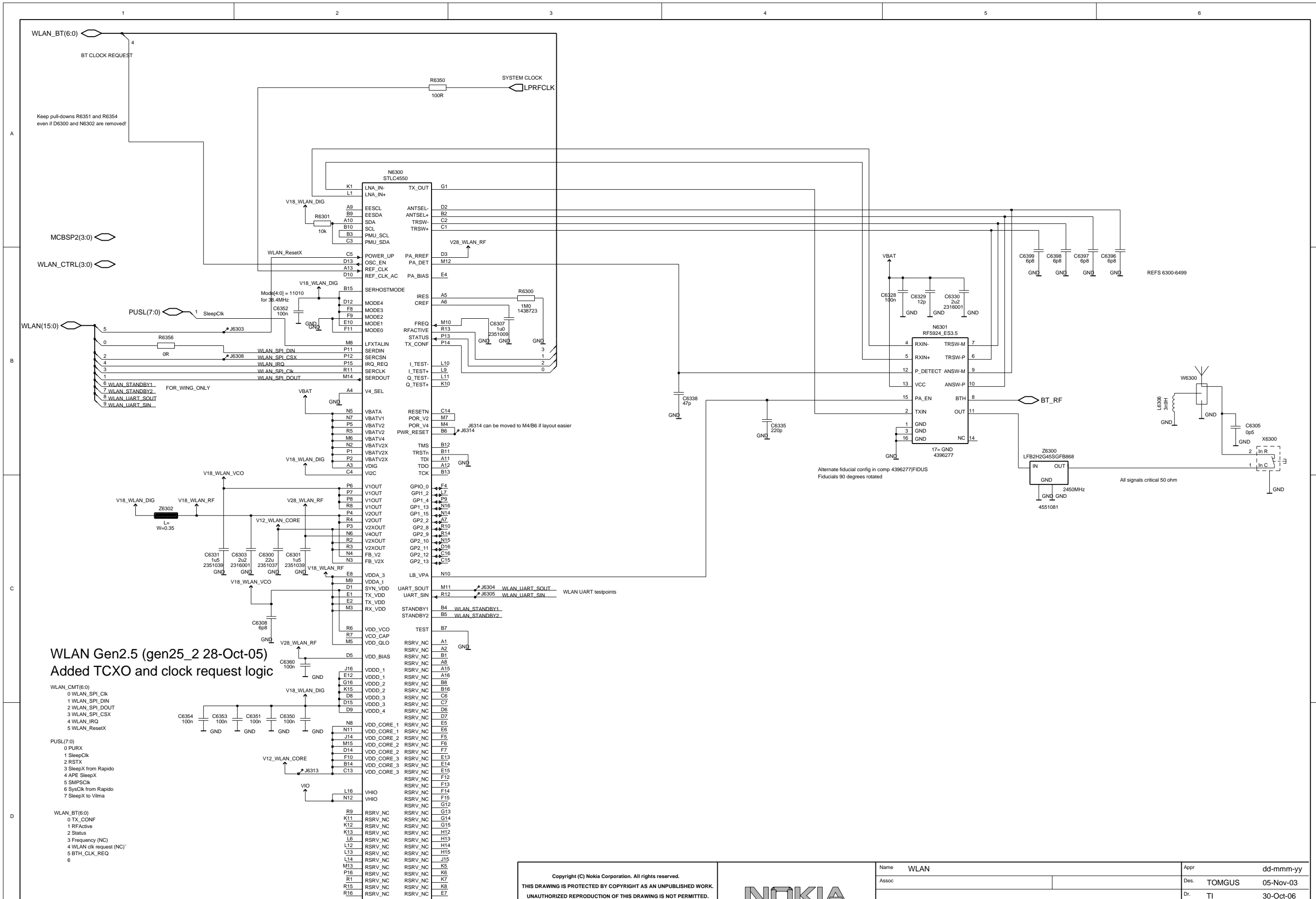

WLAN Gen2.5 (gen25_2 28-Oct-05)
Added TCXO and clock request logic

- WLAN_CMT(8:0)
 - 0 WLAN_SPI_Clk
 - 1 SleepCk
 - 2 WLAN_SPI_DIN
 - 3 WLAN_SPI_DOUT
 - 4 WLAN_SPI_CSX
 - 5 WLAN_IRQ
 - 6 WLAN_ResetX
- PUSL(7:0)
 - 0 PURX
 - 1 SleepCk
 - 2 RSTX
 - 3 SleepX from Rapido
 - 4 APE SleepX
 - 5 SMPSCk
 - 6 SysCk from Rapido
 - 7 SleepX to Vima
- WLAN_BT(6:0)
 - 0 TX_CONF
 - 1 RFActive
 - 2 Status
 - 3 Frequency (NC)
 - 4 WLAN clk request (NC)
 - 5 BTH_CLK_REQ
 - 6

GND PINS= GND 4396287

Copyright (C) Nokia Corporation. All rights reserved.
 THIS DRAWING IS PROTECTED BY COPYRIGHT AS AN UNPUBLISHED WORK.
 UNAUTHORIZED REPRODUCTION OF THIS DRAWING IS NOT PERMITTED.
 THIS DRAWING CONTAINS PROPRIETARY AND CONFIDENTIAL INFORMATION.
 This document is property of Nokia Corporation



Name	WLAN	Appr	dd-mmm-yy
Assoc		Des.	TOMGUS 05-Nov-03
		Dr.	TI 30-Oct-06
File	/nokia/sa_nmp/groups/p3047/rm-208/1yb/1yb_hw/ape/ape_if/wlan		
Proj	MARS	Sheet	xx of yy 0 (01)
		Print	Yes v. 0.0 Edit 41

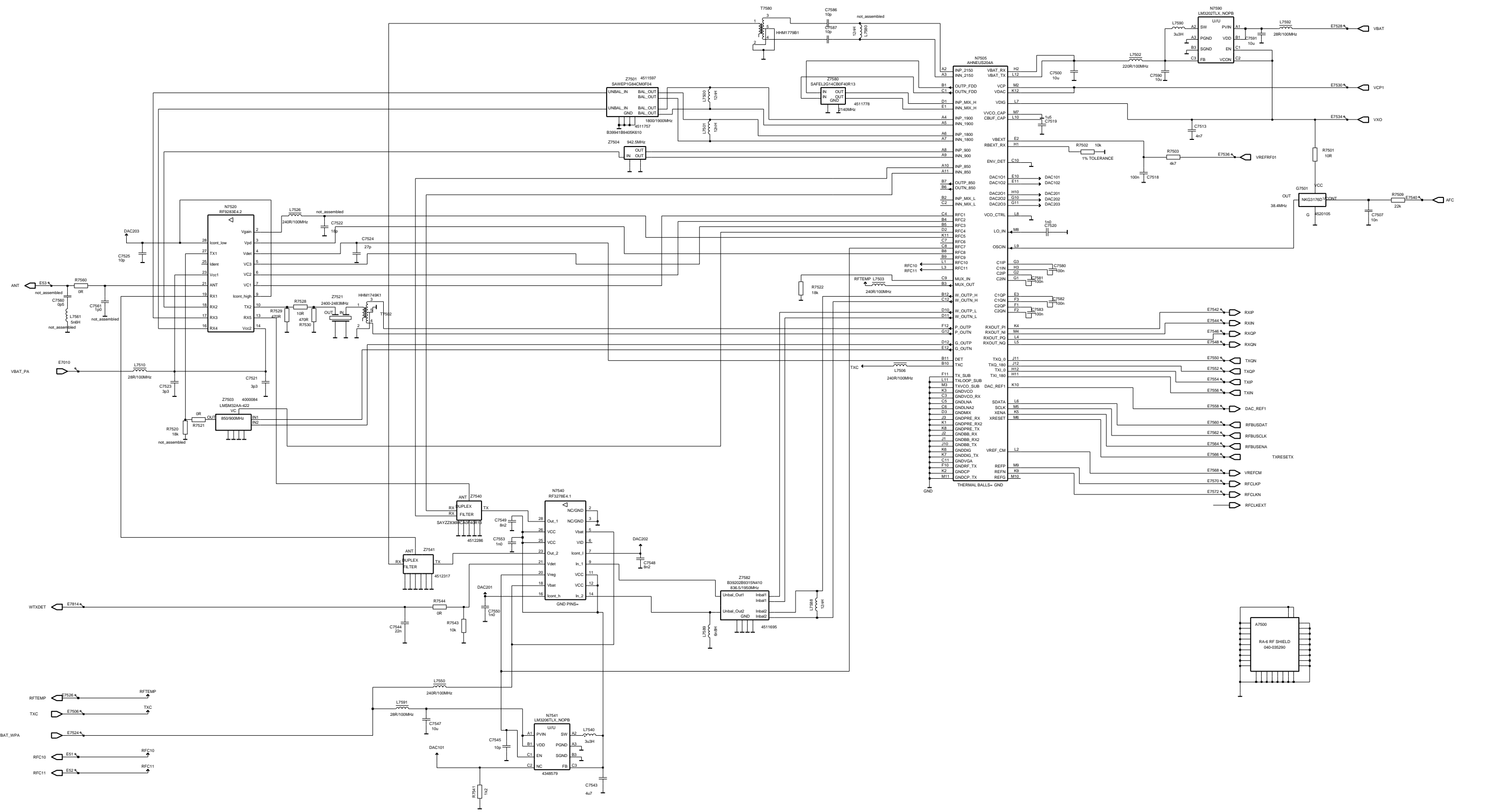

Mutant for Xtra ground tuning to cover Qband GSM + EU WCDMA

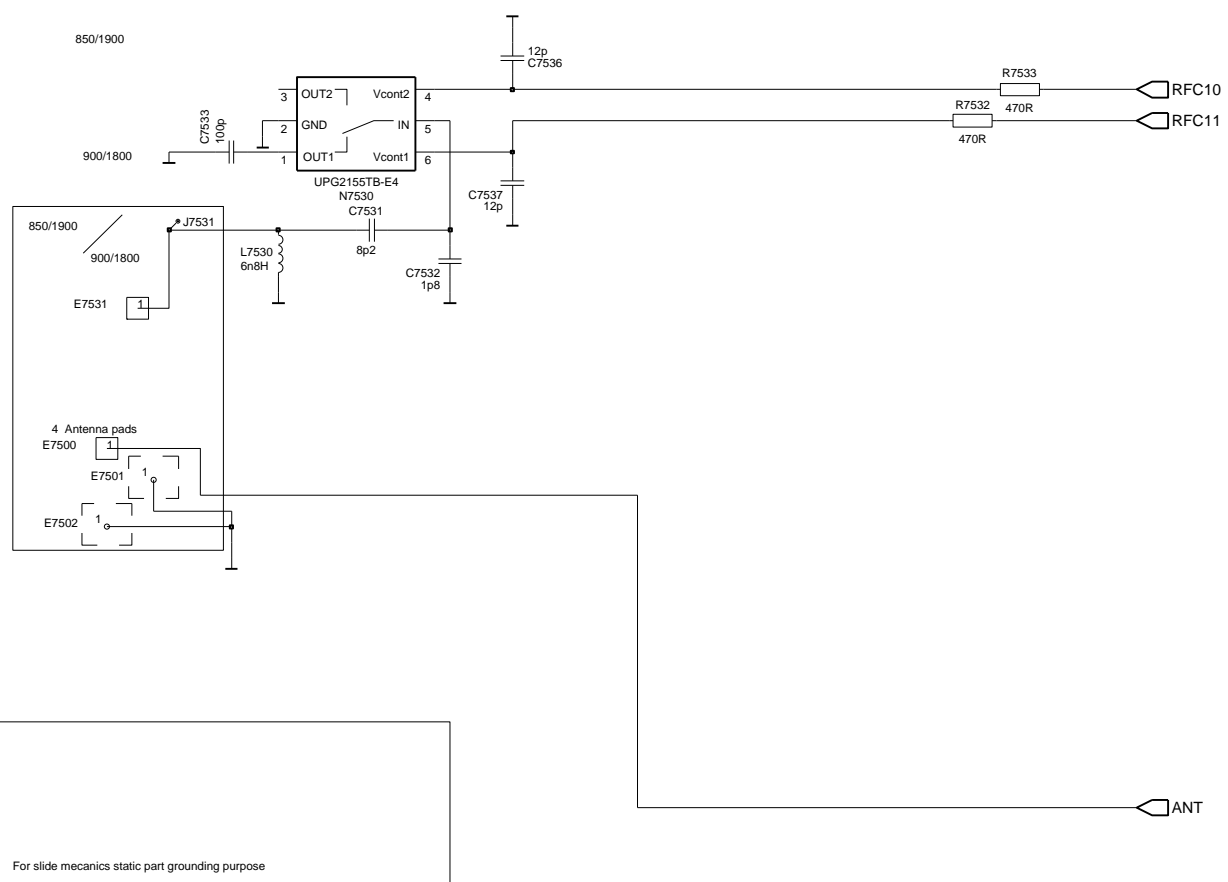

Copyright (C) Nokia Corporation. All rights reserved.
 THIS DRAWING IS PROTECTED BY COPYRIGHT AS AN UNPUBLISHED WORK.
 UNAUTHORIZED REPRODUCTION OF THIS DRAWING IS NOT PERMITTED.
 THIS DRAWING CONTAINS PROPRIETARY AND CONFIDENTIAL INFORMATION.
 This document is property of Nokia Corporation



Name	Afrodite antenna interface	Appr	dd-mmm-yy
Assoc	Mutant	Des.	TI 30-Jan-06
		Dr.	TI 21-Dec-06
File	/nokia/sa_nmp/groups/p3047/rm-208/1yb/1yb_07/ant_band	Sheet	xx of yy 0 (01)
Proj	P3047 Afrodite	Print	Yes v. 0.0 Edit 2

